

SINAPSI S.r.l.

Via delle Querce 11/13

06083 Bastia Umbra (PG) Italy

T.+39 075 8011604 F.+39075 8014602

www.sinapsitech.it | info@sinapsitech.it



EQUOBOX SIN.EQRTUEVO2T Datalogger for meters with W.M-Bus 868 MHz / OMS EN13757 protocol (through concentrators with Mesh Network technology) / wired.

User Guide

Rev 1.0



This manual refers to the Firmware starting from:

- WI: 3.67
- FW: 6.3_2.1_3.2

CONTENTS

.....	1
1. OVERVIEW	6
1.1. Device functions	6
1.2. M-Bus properties.....	6
1.2.1 Wired M-Bus.....	6
1.2.2 Wireless M-Bus	6
2. MOUNTING	7
3. CONNECTIONS	7
3.1. SIN.EQRTUEVO2T.....	7
4. ENGINEERING.....	9
4.1. Topology	9
4.1.1 Wired M-Bus devices.....	9
4.1.2 Wireless devices	10
4.2. Operation modes	11
4.2.1 SIN.EQRTUEVO2T with level converters	11
4.2.2 SIN.EQRTUEVO2T with gateways	12
4.2.3 Combined plants	12
4.2.4 Readout data.....	12
4.3. Power supply.....	13
4.4. M-Bus	13
4.4.1 M-Bus addressing.....	13
4.4.2 Sizing the wired M-Bus plant	13
4.4.3 Bus expansion	13
4.4.4 Signal specifications	13
5. INSTALLATION	14
5.1. Connect SIN.EQRTUEVO2T and level converter	14
5.2. Connect SIN.EQRTUEVO2T and gateway.....	14
5.3. Connect SIN.EQRTUEVO2T to PC.....	14
5.4. Connect M-Bus devices to SIN.EQRTUEVO2T	14
5.5. Digital inputs on SIN.EQRTUEVO2T	15
5.6. Digital outputs on SIN.EQRTUEVO2T	15
6. COMMISSIONING.....	16
6.1. Connect SIN.EQRTUEVO2T to PC or LAN.....	16
6.2. Connect SIN.EQRTUEVO2T to PC via Wi-Fi	17
6.3. M-Bus startup using the level converter on SIN.EQRTUEVO2T	18

6.4. Commission gateway on SIN.EQRTUEVO2T	19
6.5. SIN.EQRTUEVO2T troubleshooting	19
7. SIN.EQRTUEVO2T: OPERATION ON THE DEVICE	20
7.1. Select default operating language	20
7.2. Buttons	20
7.3. Operating.....	21
7.4. Main menu	22
7.4.1 System info menu	23
7.4.2 Wired meters menu	24
7.4.3 Wired search menu.....	26
7.4.4 RF search menu.....	27
7.4.5 Settings menu.....	28
7.4.5.1 System	28
7.4.5.2 LAN.....	29
7.4.5.3 RF network.....	29
7.4.5.4 Wi-Fi	29
8. SIN.EQRTUEVO2T BROWSER OPERATION	30
8.1. Registration and access, activation of Web Access service	30
8.1.1 Initial registration	30
8.1.2 Access Service Activation.....	32
8.2. Home.....	33
8.2.1 Select the datalogger language	34
8.3. Plant status.....	34
8.3.1 System status.....	34
8.3.1.1 System Information	34
8.3.1.2 Event log.....	35
8.3.1.3 Web Access	37
8.3.2 Wired devices.....	38
8.3.3 Wireless devices	39
8.3.4 Inputs/Outputs	40
8.4. Settings	41
8.4.1 System	41
8.4.1.1 Plant data	41
8.4.1.2 Alarms.....	42
8.4.1.3 System settings	42
8.4.1.4 Maintenance	43

8.4.1.5 Backup / restore	43
8.4.2 Network	45
8.4.2.1 Network settings	45
8.4.2.2 Email configuration.....	46
8.4.2.3 Dynamic DNS.....	47
8.4.3 Wired devices.....	48
8.4.3.1 Devices settings.....	48
8.4.3.2 Device search: M-Bus line M1M2 / M-Bus line ABC.....	51
8.4.4 Wireless devices	55
8.4.4.1 Device settings.....	55
8.4.4.2 Device Search	59
8.4.5 Inputs/Outputs	62
8.5.Export data	63
8.5.1 Manual reports	63
8.5.1.1 Create report	63
8.5.2 Automatic reports	65
8.5.2.1 Report interval.....	65
8.5.2.2 Set up FTP server for automatic report transmission.....	66
8.5.2.3 Set up email address for automatic report transmission	66
8.5.2.4 Selecting report type	67
8.5.3 Creating reports	67
8.5.3.1 Email	68
8.5.3.2 Standard report.....	68
8.5.3.3 Customized report.....	68
8.5.3.4 Report "All data"	68
8.5.3.5 Trend Report.....	69
8.6.User account	70
8.6.1 User configuration	70
8.6.1.1 New User.....	70
8.6.1.2 User access logging.....	71
8.6.2 Log off.....	71
9. WEB SERVICES: RESTful API	72
10.APPENDIX.....	73
10.1. Router configuration	73
9.1.1 Port forwarding	73

10.2. Open Source Software	73
9.2.1 License information	73
9.2.2 Tools for packages upgrading	74
10.3. Web Access	74

Acronyms

Dynamic DNS	Dynamic Domain Name System
LAN	Local Area Network
M-Bus	Meter Bus
W.M-Bus	Wireless Meter Bus
USB	Universal Serial Bus
VPN	Virtual Private Network
SGH NET	Sinapsi Global Hub Net

1. OVERVIEW

1.1. Device functions

The SIN.EQRTUEVO2T reads M-Bus devices connected directly to the SIN.EQRTUEVO2T as well as M-Bus devices connected to the SIN.EQRTUEVO2T via level converters as well as W.M-Bus devices connected to the SIN.EQRTUEVO2T via gateway.

It can be used:

- Alone with up to 20 directly connected (*), wired M-Bus devices
- As a master on the M-Bus Master M1M2 line by connecting up to 6 level converters for up to 250(**) M-Bus logic devices
- As a master on the ABC line by connecting up to 6 level converters for up to 250 M-Bus logic devices
- As a master on the M-Bus network with up to 23 level converters and 500 wireless devices per converter

* Device means an M-Bus load unit (≤ 1.5 mA)

** In case of connection with Wireless M-Bus gateway to M-Bus, the M-Bus M1M2 line supports a maximum of 2500 serial numbers. The maximum total number of serial numbers (wireless + cable) managed, however, remains 3000.

1.2. M-Bus properties

1.2.1 Wired M-Bus

The M-Bus system (Meter Bus) is a communications protocol per EN13757-2.

It has the following benefits:

- Highly secure data transmission
- Low wiring costs
- Can be greatly expanded without additional amplifiers
- High number of connectable devices
- Recognizes both battery-powered as well as mains powered devices
- Automated device recognition
- A very large number of systems and devices available
- Various bus topologies can be used (line, bus, star, or tree topology)

1.2.2 Wireless M-Bus

The wireless M-Bus system communicates using the communications protocol per EN13757-4.

The system also has the following benefits:

- Various network topologies available for radio read out
- The system can be extended over a large area using additional gateways
- Optimum connection by the gateway to the SIN.EQRTUEVO2T (mesh network)

2. MOUNTING

It is designed for mounting on 35 mm rails.

It takes up the equivalent of four standard modules on the rails.

Additional information on mounting is available in the mounting instructions for the SIN.EQRTUEVO2T.

3. CONNECTIONS

3.1. SIN.EQRTUEVO2T

The SIN.EQRTUEVO2T has the following connection terminals / LEDs.

<p>The diagram illustrates the connection terminals and interface of the SIN.EQRTUEVO2T. At the top, there are five terminal pairs labeled A through E. Terminal A is for Ethernet, B for USB, C for Antenna, and D for RS232/M-Bus. Below this is a control panel with a display and buttons. The bottom section shows terminals I, H, F, G, and E for digital inputs/outputs and power.</p>	A	Ethernet connection
	B	USB connection (no function)
	C	Antenna connection
	D	Terminals (1), (2) and (3): Connections via RS232 for following level converters (A = RX; B = TX; C = GND) Terminals (4) and (5): Connections M1 and M2 for M-Bus devices and follow-on level converters
	E	Terminals (16) and (17): Power supply AC/DC 24 V
	F	Terminals (12) and (13): Relay connections for digital output 1, max. AC/DC 30 V
	G	Terminals (14) and (15): Relay connections for digital output 2, max. AC/DC 30 V
	H	Terminals (9), (10) and (11): Connections for digital inputs. Terminal (8): reference for digital inputs
	I	Terminals (6) and (7) are not used. Do not apply electricity to these terminals

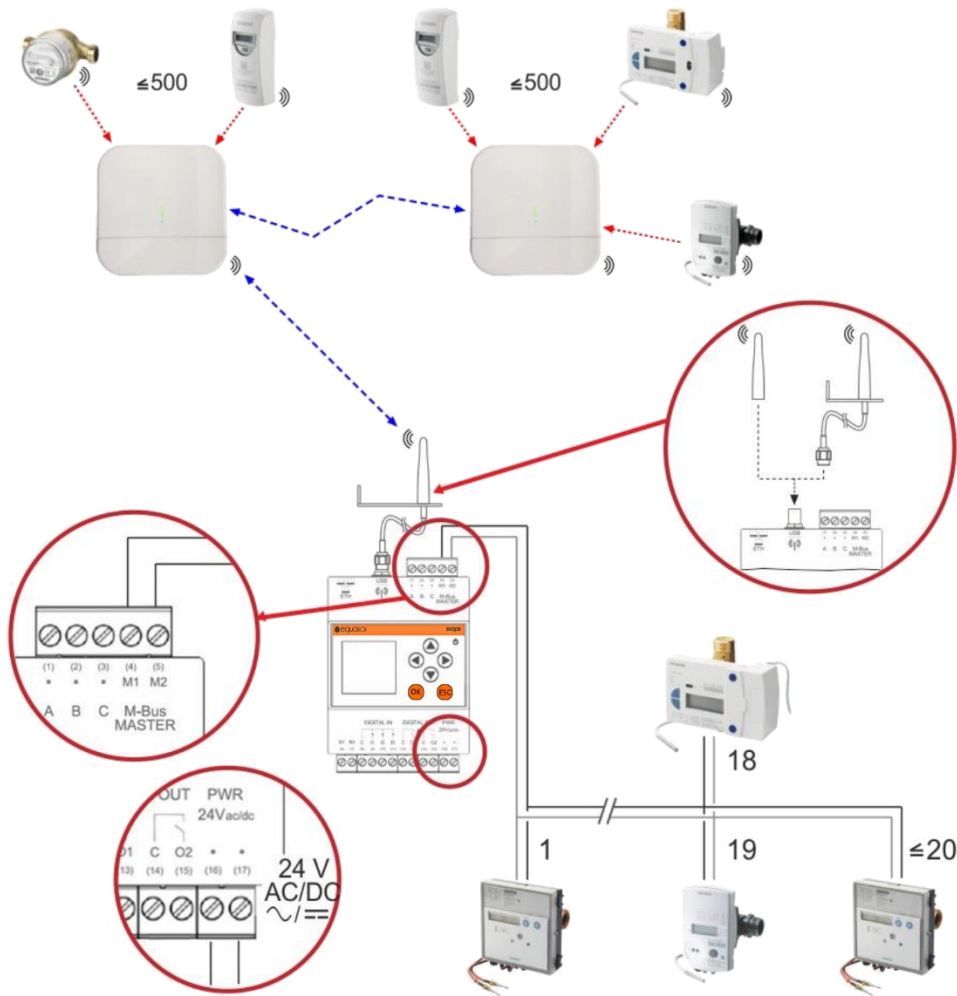

Terminals (1) and (2) on the level converter are connected to line M1M2 on the M-Bus datalogger. In addition, a maximum of 20 M-Bus devices can be connected directly to terminals M1 and M2.

To connect the level converter to the M-Bus datalogger on ABC, connect the terminals A (3), B (4) and C (5) of the SIN.EQLC1 or A (5), B (6) and C (7) SIN.EQLC250 to terminals A (1), B (2), C (3) of the M-Bus datalogger.

Important: M-Bus devices cannot be connected directly to terminals A, B, C.

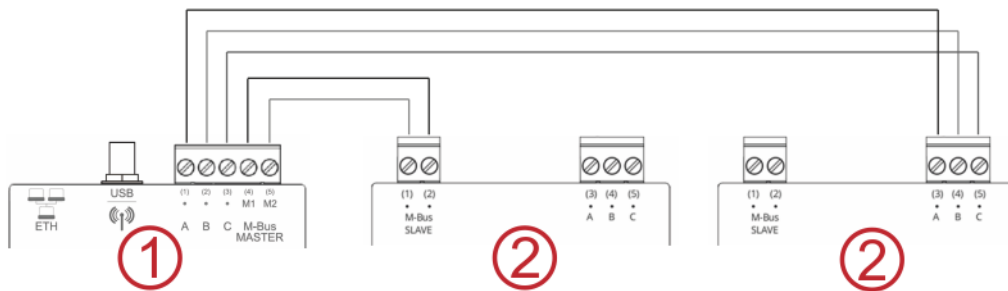

- 1 Datalogger as master for 20 devices
- 2 Level converter as slave for additional M-Bus devices

4. ENGINEERING

4.1. Topology

4.1.1 Wired M-Bus devices

The M-Bus permits various network topologies. The devices can be connected to the level converter or the SIN.EQRTUEVO2T in a line, bus, star, or tree topology, or a combination thereof.

Ring topology is not permitted. Bus cable polarity is not relevant, simplifying installation.

Star topology



Tree topology

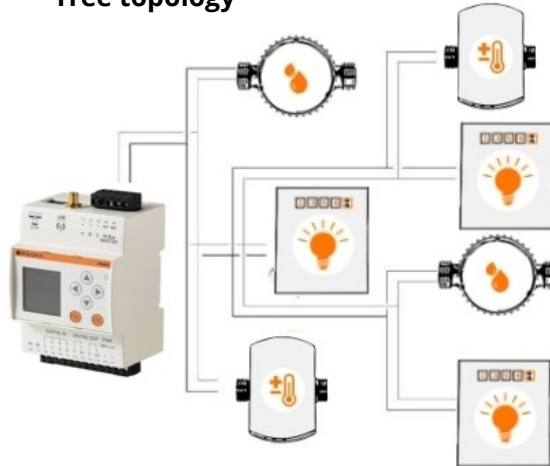

Line topology

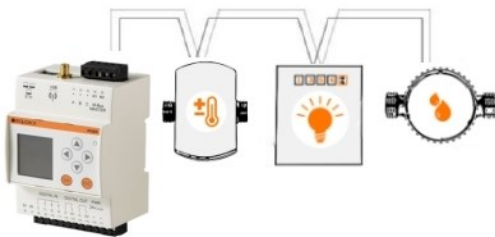

Bus topology

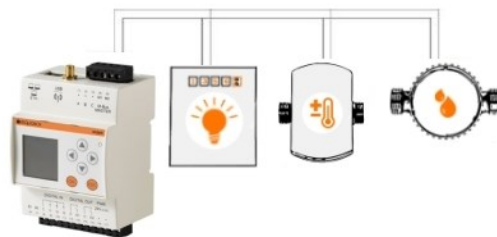

Combination of topologies

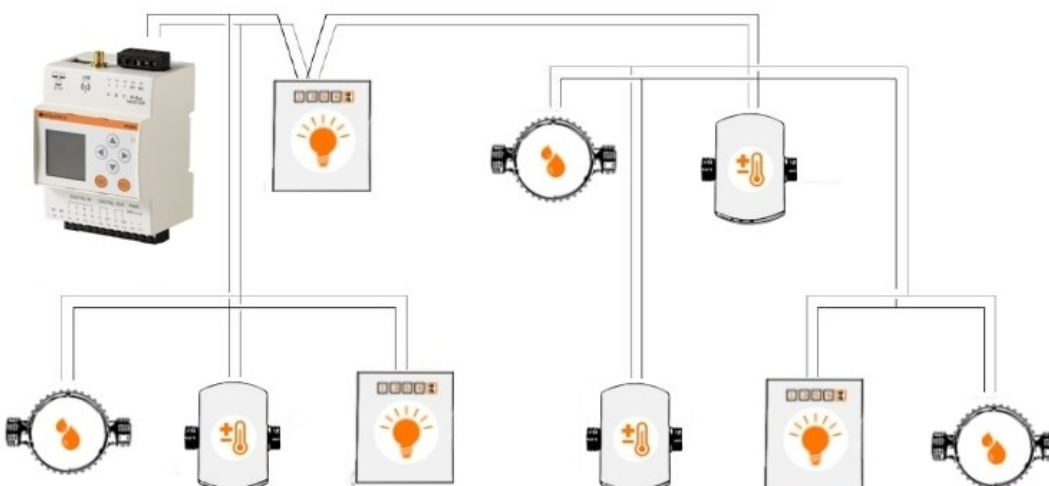

Ring topology

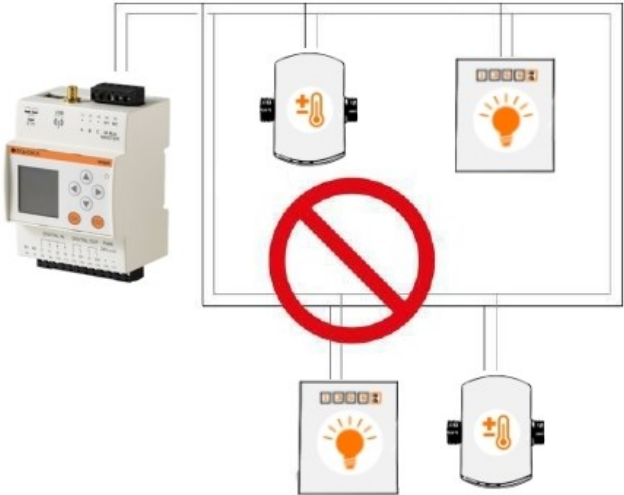

4.1.2 Wireless devices

The SIN.EQRTUEVO2T permits read out using various network topologies. The gateways are self-organizing and search for the optimum connection to the datalogger.

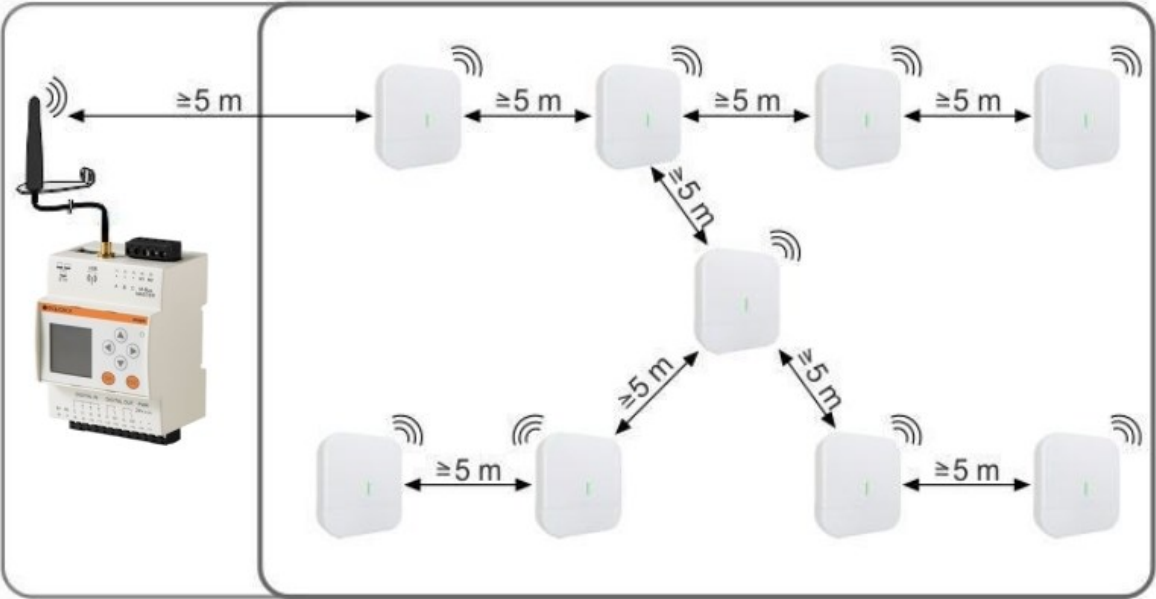

4.2. Operation modes

The SIN.EQRTUEVO2T is used to read up to 20 directly connected devices (20 units M-Bus loads (*)). A PC / Internet browser reads the data either locally over Ethernet or from anywhere over the Internet.

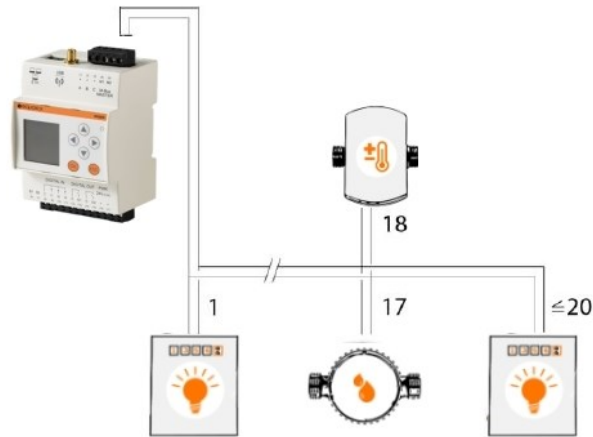

(*) 1 M-Bus load $\leq 1,5$ mA

4.2.1 SIN.EQRTUEVO2T with level converters

The datalogger is equipped with additional level converters over two lines to extend the system by up to 500 logical M-Bus devices (max. 250 per line). In case of connection with Wireless M-Bus gateway to M-Bus, the M-Bus M1M2 line supports a maximum of 2500 serial numbers. The maximum total number of serial numbers (wireless + cable) managed, however, remains 3000.

The datalogger is operated as the master. Up to 20 M-Bus devices (20 units M-Bus loads) can be directly connected (Line M1M2).

The level converters are connected as slaves to the datalogger SIN.EQRTUEVO2T. Up to 60 M-Bus devices (60 units M-Bus loads) can be connected to the level converter SIN.EQLC1 and up to 250 M-Bus devices can be connected to the level converter SIN.EQLC250 (250 simple M-Bus loads).

A maximum of six level converters (SIN.EQLC1, SIN.EQLC250) can be connected to each line with a maximum of 250 M-Bus devices per line.

Moreover, up to 20 M-Bus devices can be connected directly to terminals M1 and M2.

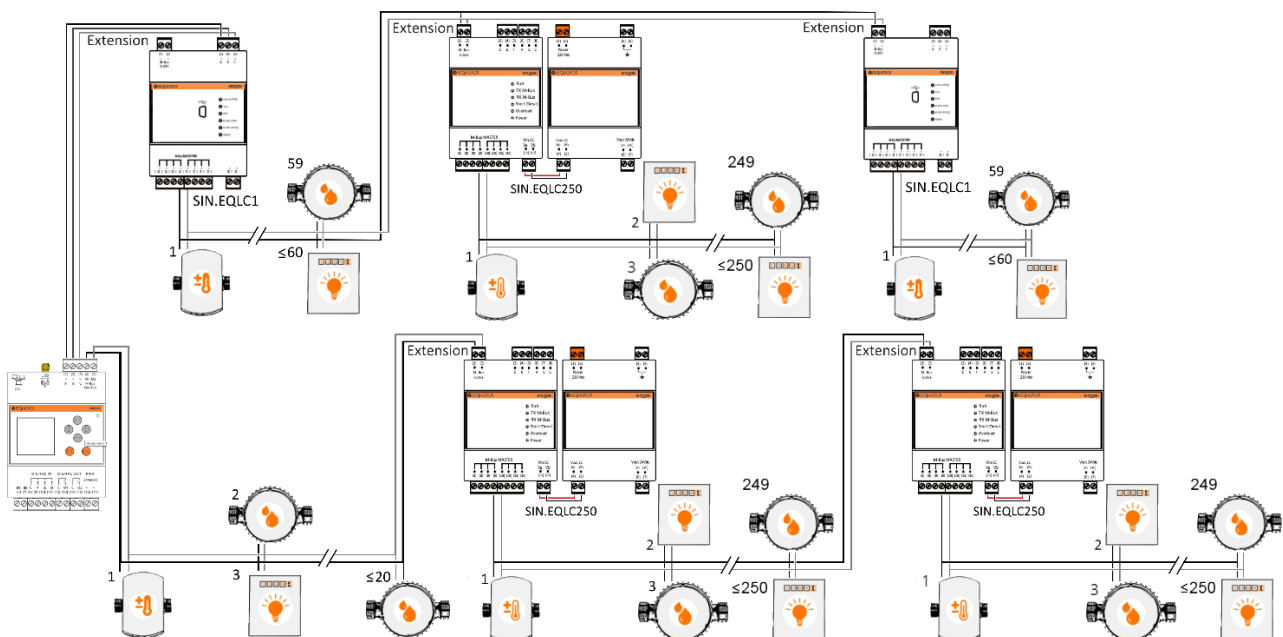

4.2.2 SIN.EQRTUEVO2T with gateways

The SIN.EQRTUEVO2T can be equipped with additional gateways to extend the system up to 2.500 wireless devices. Communication between the SIN.EQRTUEVO2T and gateways takes place over a mesh RF protocol (backbone network). A minimum of one M-Bus SIN.EQRTUEVO2T and one gateway is required to read out wireless devices. The backbone RF network can consist of a maximum of 23 gateways. Communication between the gateways and wireless devices takes place over the W. M-Bus protocol. The gateways save the consumption data from the devices in its environment, while forwarding the data to other gateways, up to the SIN.EQRTUEVO2T (the other gateways act as repeaters in this case).

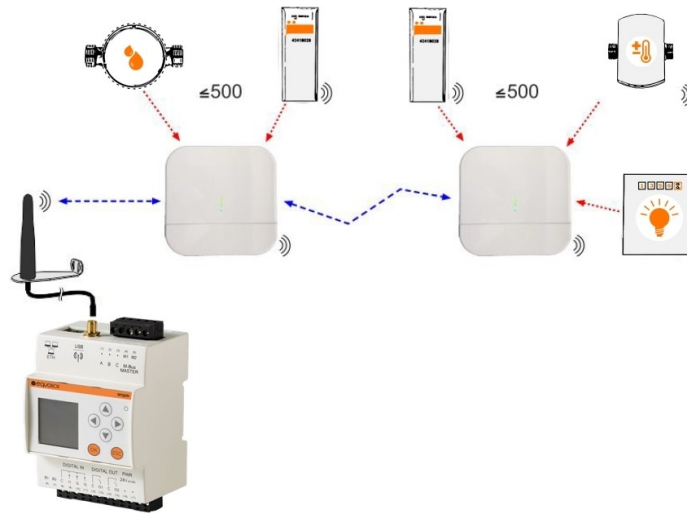

4.2.3 Combined plants

One SIN.EQRTUEVO2T can read out up to 500 wired and 2.500 wireless devices.

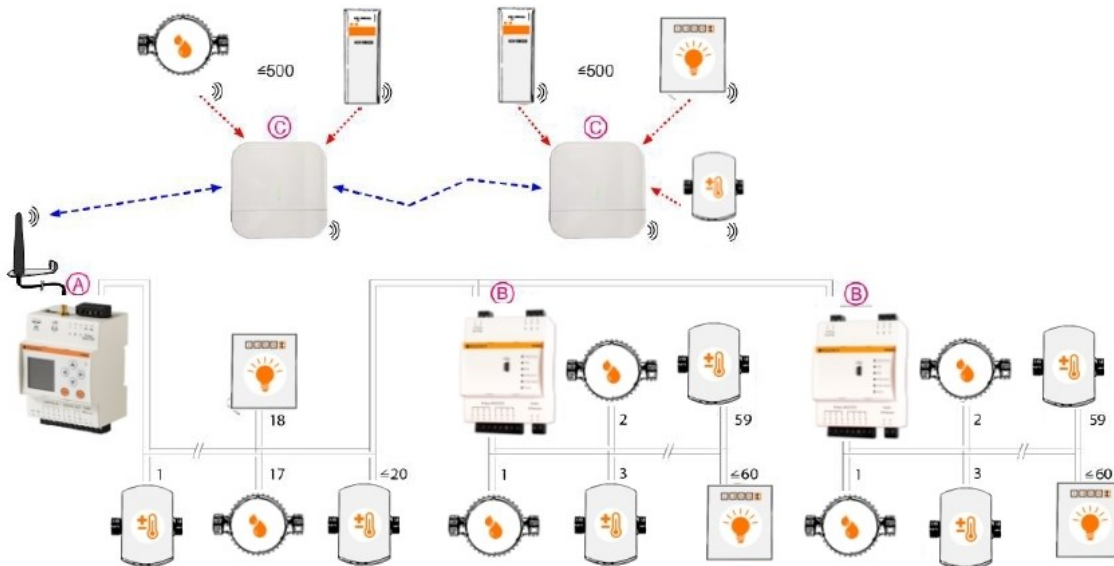

- A** SIN.EQRTUEVO2T as master
- B** Lever converter as slave (on ABC bus or M-Bus)
- C** W. M-Bus gateway as participant

4.2.4 Readout data

A PC/Internet browser reads the data on all operation modes either locally over Ethernet or from anywhere over the Internet using a PC/Internet browser.

4.3. Power supply

Select an AC/DC 24 V power supply with at least 14.5 / 15 VA and voltage tolerances as described in the technical data.

4.4. M-Bus

4.4.1 M-Bus addressing

M-Bus uses two addressing types to recognize and communicate with wired M-Bus devices:

- Primary addressing:
Up to 250 primary addresses can be assigned to an M-Bus primary. The primary address is normally assigned during M-Bus device commissioning.
- Secondary addressing:
Secondary addressing consists of 8 bytes and permits the assignment of any number. In the default setting, the secondary address for a M-Bus device matches the serial number issued by the device manufacturer. The assignment prevents address conflicts on the M-Bus and permits addressing of more than 250 M-Bus devices on a plant.

4.4.2 Sizing the wired M-Bus plant

Allowable cable types:

- Shielded telephone cable 0.5 mm² (4 x 0.8 mm)
- NYM cable (1.5 mm²)
- Maximum capacitive cable load of 152 nF/km

4.4.3 Bus expansion

If using cable with a cross-section of 0.6 mm², you must cut the information in half on "Maximum distance" and "Number of devices" from the following table.

Plant type	Maximum distance	Total cable length	Cable diameter	Number of devices (slaves)	Max. transmission rate
Small residential buildings	350 m	1000 m	0.8 mm ²	250	9600 Baud
Large residential buildings	350 m	4000 m	0.8 mm ²	250	2400 Baud
				64	9600 Baud
Small developments	1000 m	4000 m	0.8 mm ²	64	2400 Baud
Large developments	3000 m*	5000 m	1.5 mm ²	64	2400 Baud
Direct vicinity	5000 m*	7000 m	1.5 mm ²	16	300 Baud
Point-to-point connection	10000 m*	10000 m	1.5 mm ²	1	300 Baud

*Shielded cabling required at a distance in excess of 1000 m (see EN13757-2 appendix E).

4.4.4 Signal specifications

M-Bus	Condition	Minimum	Typical	Maximum	Unit of measure
Transfer rate	$C_{segment} \leq 382nF$	300	2400	9600	Baud
Bus current	SIN.EQRTUEVO2T	0		30	mA

5. INSTALLATION

Prerequisite

Connections between devices are based on the selected operating mode as illustrated in the sections below.

Important: Do not connect power to the devices prior to installation!

5.1. Connect SIN.EQRTUEVO2T and level converter

Terminals (1) and (2) on the level converter are connected to terminals M1 (4) and M2 (5) on the M-Bus SIN.EQRTUEVO2T.

Terminals A (3), B (4) and C (5) on the level converter are connected to terminals A (1), B (2) and C (3) on the M-Bus SIN.EQRTUEVO2T.

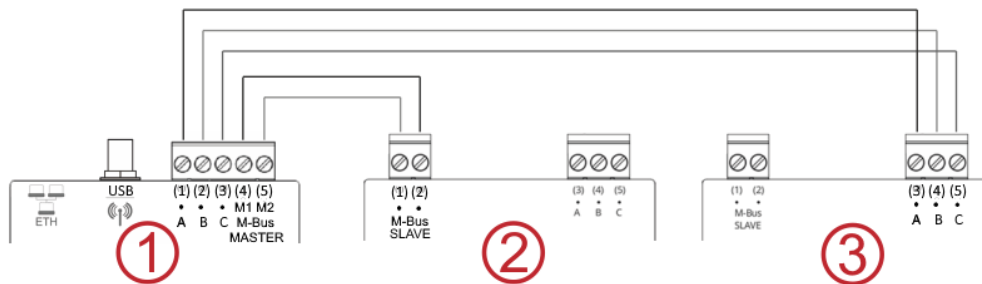

- 1 SIN.EQRTUEVO2T as master for 20 devices (see paragraph 5.4)
- 2 Level converter as slave for an additional 60 (using LC1) or 250 (using LC250) devices
- 3 Level converter connected via ABC as slave for an additional 60 (using LC1) or 250 (using LC250) devices

5.2. Connect SIN.EQRTUEVO2T and gateway

Install the supplied antenna to access the gateway. By setting identical mesh network parameters both in the SIN.EQRTUEVO2T and in the gateway, W.M-Bus devices can be received. See paragraph 8.4.4.1 Device settings.

5.3. Connect SIN.EQRTUEVO2T to PC

A network cable is used to connect the SIN.EQRTUEVO2T and PC/LAN. See Connect SIN.EQRTUEVO2T to PC or LAN

5.4. Connect M-Bus devices to SIN.EQRTUEVO2T

Up to 20 devices can be connected directly to the SIN.EQRTUEVO2T. They are connected to terminals M1 (4) and M2 (5).

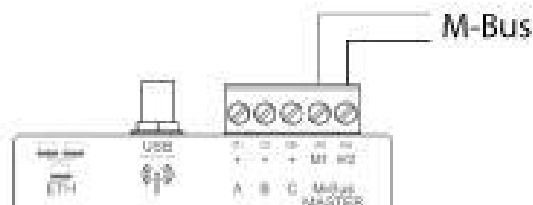

5.5. Digital inputs on SIN.EQRTUEVO2T

SIN.EQRTUEVO2T provides 3 digital inputs I1, I2, and I3 to connect potential-free contacts (e.g. switches, relays). The contacts are connected as follows:

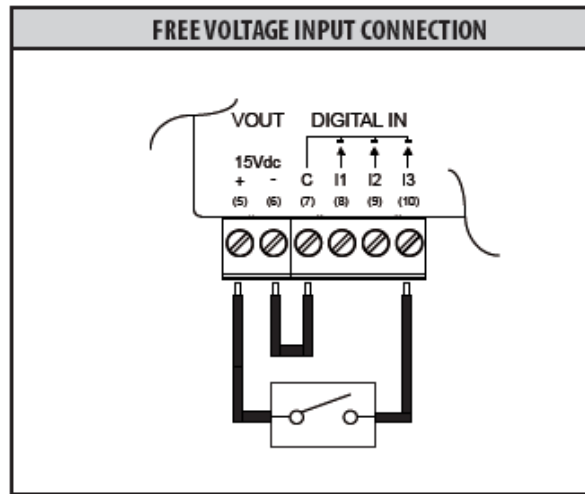

- Input I1:
Connect the external contact with terminals C (8) and I1 (9).
- Input I2:
Connect the external contact with terminals C (8) and I2 (10).
- Input I3:
Connect the external contact with terminals C (8) and I3 (11).

5.6. Digital outputs on SIN.EQRTUEVO2T

The SIN.EQRTUEVO2T has two relays that can be used as digital outputs. They can connect a load or be used as contacts to activate other systems. Terminals O1 (13) and O2 (15) can be controlled locally on the SIN.EQRTUEVO2T or remotely via the Internet (see section **8.3.4 Inputs/Outputs**).

Connect as follows to control, for example, a load:

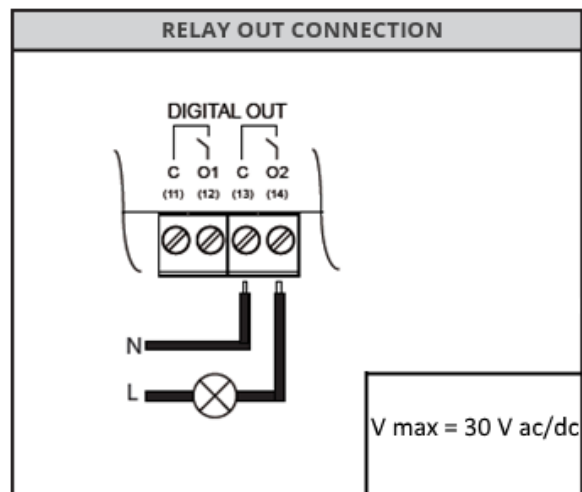

6. COMMISSIONING

Prerequisites

Ensure the following prior to commissioning the SIN.EQRTUEVO2T:

- The electrical connection must be fused (fuse or circuit breaker) The power supply must be at the device's rated voltage.
The power supply must be sufficient to operate the device.
- The router (if available) must be configured as per the description.
- The network plug must be wired correctly to exchange data and connected to the ETH connection on the SIN.EQRTUEVO2T
- In the event a level converter is connected to the SIN.EQRTUEVO2T, connect it as a slave on the SIN.EQRTUEVO2T's master output.

6.1. Connect SIN.EQRTUEVO2T to PC or LAN

SIN.EQRTUEVO2T has an Ethernet connection to directly connect to a local PC or connection to a PC over LAN.

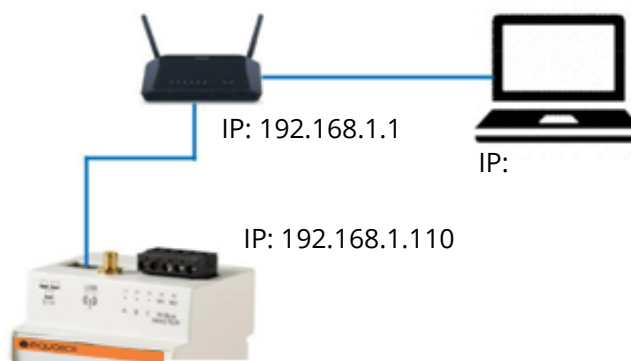

Default settings for connecting to the SIN.EQRTUEVO2T:

IP address: 192.168.1.110
 Network mask: 255.255.255.0
 IP address assignment: Static

Proceed as follows to connect a PC to SIN.EQRTUEVO2T:

- Use an Ethernet cable per standard T568A or T568B (1:1 or crossover) to connect SIN.EQRTUEVO2T with a PC (directly) or LAN. If using the LAN, also connect the PC to the LAN.
- Check whether an IP address is displayed on SIN.EQRTUEVO2T in menu **System info**, under **LAN Status**.

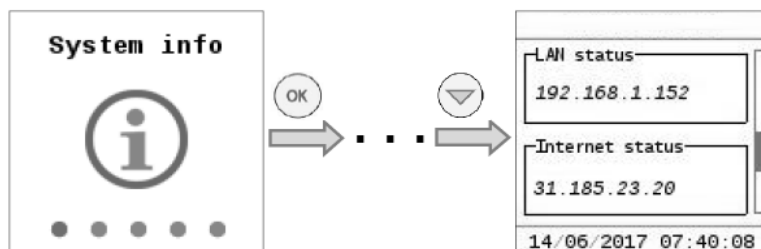

- Connection over LAN Use a DHCP server for dynamic IP address or a fixed IP address if the PC and SIN.EQRTUEVO2T are integrated on an existing LAN. Contact your network administrator about the fixed or dynamic IP address to be used. You can change the LAN settings via the local operation of the SIN.EQRTUEVO2T.
- Direct PC connection Configure the IP address on the PC network settings or SIN.EQRTUEVO2T so that the PC and SIN.EQRTUEVO2T are on the same network. In the example above, the PC must have a static IP address 192.168.1.xxx (with xxx of 1 and 254, but NOT 110) and the network mask must be set to 255.255.255.0.
- IP address ranges The following IP addresses are reserved for private networks:

 - Class A: 10.0.0.0–10.255.255.255.
 - Class B: 172.16.0.0–172.31.255.255.
 - Class C: 192.168.0.0–192.168.255.255 (typical for home networks).
- Access SIN.EQRTUEVO2T** **to** To access SIN.EQRTUEVO2T, enter the SIN.EQRTUEVO2T IP address (e.g. <https://192.168.1.110>) in the browser (Chrome, Safari, Firefox, Edge). Additional information on router configuration is available in the Appendix.

6.2. Connect SIN.EQRTUEVO2T to PC via Wi-Fi

The SIN.EQRTUEVO2T has a Wi-Fi connection. When Wi-Fi is activated, the datalogger creates an access point with a specific SSID (Wi-Fi name). This SSID consists of the datalogger model (SIN.EQRTUEVO2T) and its serial number (EVxxxxxxx). So, the SSID is for example SIN.EQRTUEVO2T-EV12345678. Since WiFi is enabled, it remains activated for 4 hours.

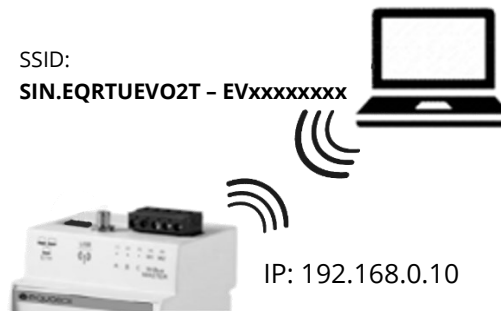

Default settings for connecting to SIN.EQRTUEVO2T:

- Wi-Fi SSID: SIN.EQRTUEVO2T-EVxxxxxxx
- IP address: 192.168.0.10
- Network Mask: 255.255.255.0
- IP address assignment: Static

Default settings for connecting to the SIN.EQRTUEVO2T:

Wi-Fi activation

Press the ESC button for more than 5 seconds

create a new access point. You can activate WiFi in two ways:

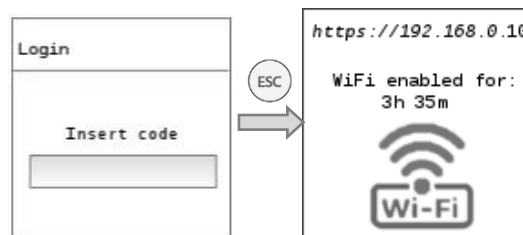

Activate from browser See section 8.3.1 System status

6.3. M-Bus startup using the level converter on SIN.EQRTUEVO2T

After installation and after all connections are established, the M-Bus is commissioned as per the following steps:

Check M-Bus

On the level converter LC1, check that the “**M-Bus Ready**” LED is on and the “**M-Bus Error**” LED is off.

On the level converter LC250, check that the “**Run**” LED is on and the “**M-Bus Error**” LED is off.

First time log in

You must set the SIN.EQRTUEVO2T language the first time SIN.EQRTUEVO2T is activated.

The following languages are currently available:





- German
- English
- Italian
- French
- Dutch

Notes

The language selected during the initial login applies to both the display as well as the software user interface of SIN.EQRTUEVO2T. You can change the language after initial login for the display and user interface of SIN.EQRTUEVO2T anytime and independently.

See section “**7.4.5 Settings menu**” (display). You can change the language for the SIN.EQRTUEVO2T at any time in the software user interface. See section “**8.2.1 Select the datalogger language**” (software interface).

Access code

Define an 8-digit access code. Use the  and  navigation buttons to set a number from 0...9. Press OK to go to the next digit. You must re-enter the 8-digit access code to confirm it.

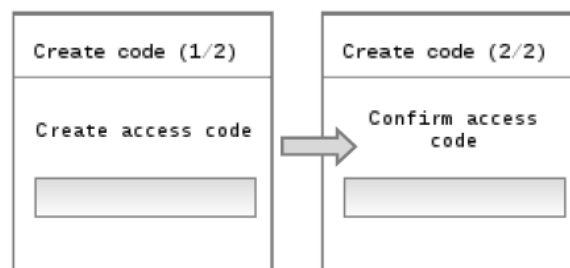

Change access code

The access code can be changed at any time to protect against unauthorized access. See paragraph “**Operating**” section “Change access code”.

Start meter search

In the **Meter search** main menu, start the search for connected M-Bus devices. Detailed information on the meter search workflow is available in section “**7.4.3 Wired search menu**”.

Continue settings on SIN.EQRTUEVO2T

At the conclusion of the meter search, we recommend accessing the SIN.EQRTUEVO2T via the Internet browser to conclude the configuration. You can enter plant data and other settings via the Internet browser. For access to SIN.EQRTUEVO2T, see section “**Connect SIN.EQRTUEVO2T to PC or LAN**”.

Enter meter name	Assign each device a unique name, e.g. "Apartment 1", "Warehouse", "Hot water" to simplify evaluation of reports with consumption data or device information. Display menu selection Settings → Wired devices → Device settings . See paragraph 8.4.3.1 Devices settings
Enter plant data	Plant data includes information on user, address, etc. The data is displayed in the report header and permits clear assignment of the measured data to a plant. Display menu selection Settings → System → Plant data , see paragraph "8.4.1.1 Plant data" .
Email settings	SIN.EQRTUEVO2T can email you reports, events, messages, anomalies, and errors. See "8.4.2.2 Email configuration" .

6.4. Commission gateway on SIN.EQRTUEVO2T

To simplify the evaluation of reports on consumption data or device information on the SIN.EQRTUEVO2T assign each device a clear and unique name to each meter, for example, "Apartment 1", "Basement", "Hot water". See Section **Settings /Wireless Devices/ Device settings**.

6.5. SIN.EQRTUEVO2T troubleshooting

The datalogger does not switch on. The green LED is off.

- Using a multimeter, check whether the required operating voltage AC/DC 24 V +/- 10 % is available between terminals (15) and (16).

The display is switched off.

- The display switches off automatically after 10 minutes. Press any button to switch on the display.

The SIN.EQRTUEVO2T does not recognize any devices.

- Check to ensure the wiring is correct between the SIN.EQRTUEVO2T and connected M-Bus devices.
- Check to ensure the wiring is correct between the SIN.EQRTUEVO2T and the level converters.
- Check M-Bus wiring for short circuits.

The SIN.EQRTUEVO2T does not recognize all M-Bus devices.

- Check to ensure the wiring is correct between the SIN.EQRTUEVO2T and unrecognized devices.
- Using a multimeter, check whether the bus voltage on the unrecognized devices is between DC 24 V and 42 V.
- Ensure that the communication settings on the SIN.EQRTUEVO2T are compatible with the M-Bus devices (transmission rate, addressing)
- Check to ensure that the number of connected M-Bus devices does not exceed the maximum permitted amount.

The SIN.EQRTUEVO2T does not recognize all radio devices.

- Ensure that the unrecognized devices are not located too far from the SIN.EQRTUEVO2T and that the radio signal is not too weakened by cement or metal walls
- Ensure that the unrecognized devices are loaded to the SIN.EQRTUEVO2T list and that contact to the wireless M-Bus devices, recognized by the SIN.EQRTUEVO2T, is not interrupted.
- Please note that some wireless M-Bus devices only transmit their data at intervals of multiple hours
- Use the web interface or the SIN.EQSW1 software to ensure that the mesh network is operational.



No connection with the SIN.EQRTUEVO2T.

- Check the PC network address. The SIN.EQRTUEVO2T uses an IP address 192.168.1.110 as the default. As a result, the PC must have an IP address of 192.168.1.xxx (with xxx not equal to 110).
- Ensure that a firewall is not blocking TCP/IP Port 80 or 443.
- Please contact your local IT administrator for excluding network problems.

7. SIN.EQRTUEVO2T: OPERATION ON THE DEVICE

7.1. Select default operating language

The language set on the display is the default language.

You can set the default operating language directly on the display. After entering the password, you can select the language on the main menu at **Settings → System → Select language** by pressing the  and  buttons.

The following languages are available:

- English
- German
- Italian
- French
- Dutch







Each time the language is set or changed on the display; it remains the default language until the next change. The default language is used on the following:

- Display functions
- SIN.EQRTUEVO2T default language for the login
- Automatic reports on all SIN.EQRTUEVO2T

Important! The language set locally on the SIN.EQRTUEVO2T is also used for sending emails and to generate reports and alarm notifications. It is very important that the language is set correctly locally on SIN.EQRTUEVO2T during commissioning.

7.2. Buttons

SIN.EQRTUEVO2T has six buttons to navigate menus on the display. The button functions are based on the displayed menu.

	<ul style="list-style-type: none"> • Confirm a field or a set value • Access to the main or sub-menu
	<ul style="list-style-type: none"> • Cancel a field selection or value • Return from a sub-menu to a main menu
	<ul style="list-style-type: none"> • Go to previous main menu or sub-menu • Move cursor to the left
	<ul style="list-style-type: none"> • Go to next main menu or sub-menu • Move cursor to the right
	<ul style="list-style-type: none"> • Scroll up one page • Select / switch from letters A...Z and digits 0...9
	<ul style="list-style-type: none"> • Scroll down one page • Select / switch from letters A...Z and digits 0...9



7.3. Operating

Measured data and basic settings are displayed on a colour display. The display switches off automatically to save energy after 10 minutes.

Access code entry

Press a navigation button to switch on the display. The display to enter the access code opens.



Enter the access code. The cursor flashes at the current position. Select individual numbers using the arrow keys  and  and confirm with the OK button. The cursor goes to the next position on the 8-digit access code.

Change access code

The access code on SIN.EQRTUEVO2T can be changed as follows:

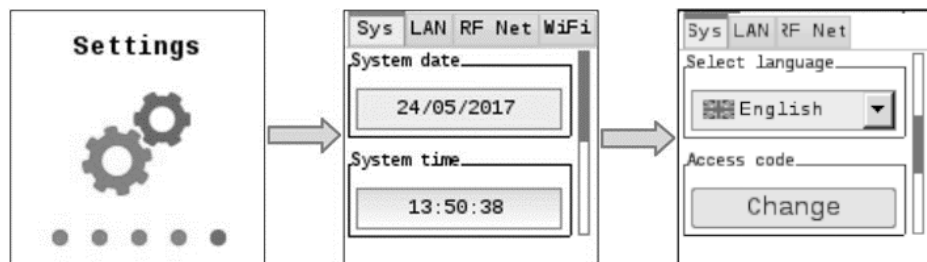

Select **Settings** → **System** → **Access Code** → **Change** and press the **OK** button to reset the access code.

The current access code must be entered before you can enter and confirm the new code.

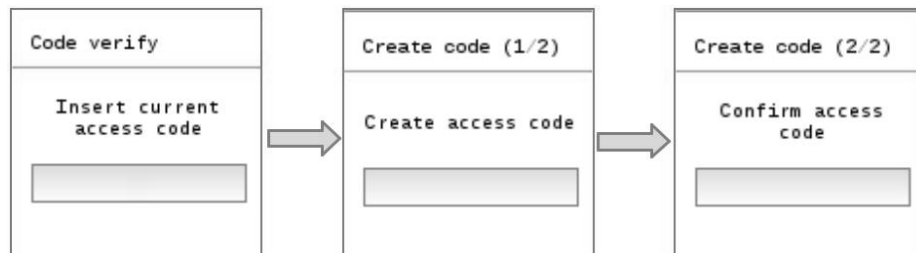

The display changes automatically to the System info main menu once the access code is changed.

The code must be entered again if an incorrect access code is entered or the new access code does not match the confirmation. There is no limit to the number of attempts.

Note

You can reset the access code for local access on SIN.EQRTUEVO2T using web access.

Important!

For security reasons, define a new access code locally on the SIN.EQRTUEVO2T as soon as possible after a reset.

7.4. Main menu

The main menu displays after correctly entering the access code. It consists of five pages: **System info**, **Wired meters**, **Wired search**, **Search RF** and **Settings**.

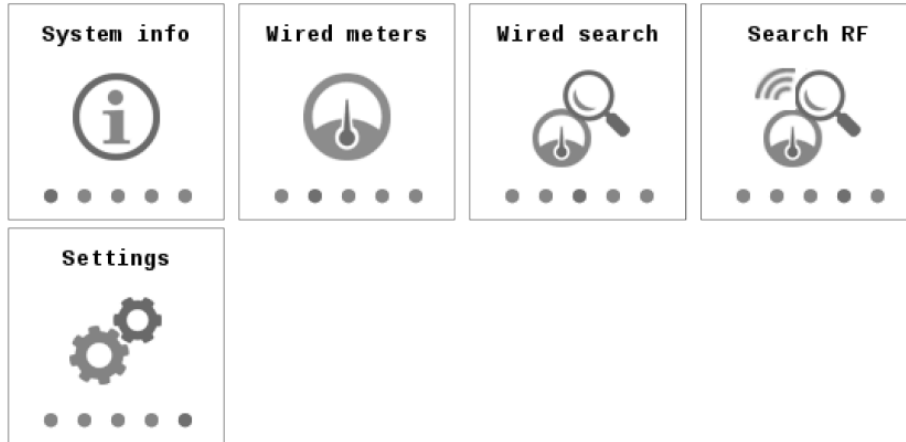

System info	Includes information on SIN.EQRTUEVO2T and connection status.
Wired meters	Displays the list of connected M-Bus devices and makes it possible to display the data.
Wired search	Starts the search for connected device as per the last saved changes.
Search RF	Starts the search for RF devices using the last saved settings.
Settings	Includes some SIN.EQRTUEVO2T settings.

7.4.1 System info menu

Select the **System info** main menu and press the **OK** button to go to the submenu

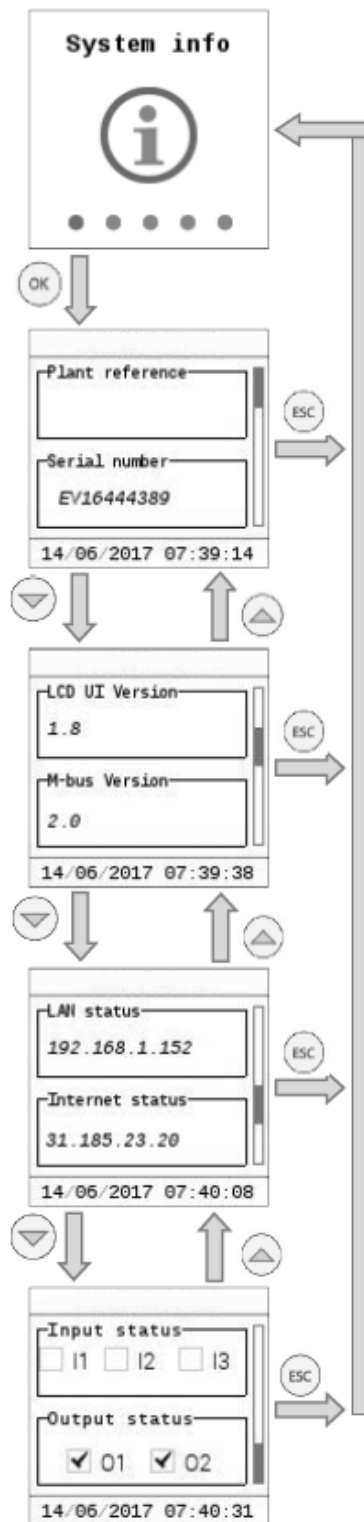

- Plant name
- Serial number (required for support calls).

- LCD UI Version (local UI version)
- M-Bus firmware version

- LAN connection status and IP address (if connection is available).
- Internet connection status and public IP address for external access (if connection is available).

- Input status (indicates the status of the three inputs)
- Output status (indicates the status of the two relay outputs)

7.4.2 Wired meters menu

Select the wired meters main menu and press **OK** to go to the sub menus.

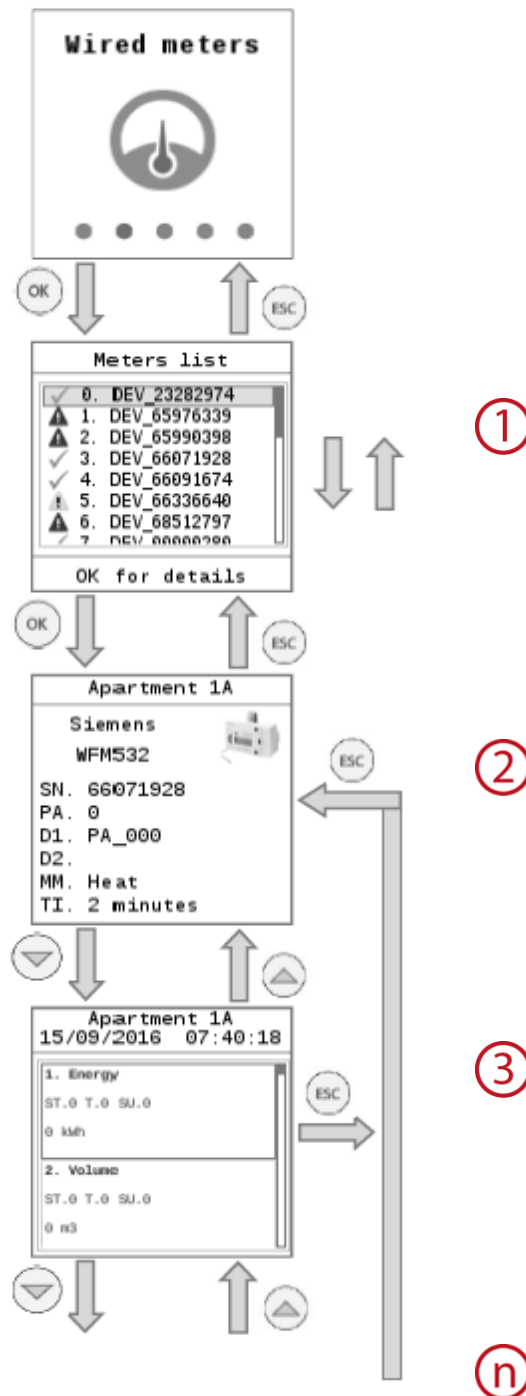

- ① List of saved meters. Each meter is identified by the first 8 digits of the serial number (e.g. 5434563).

The following symbols are displayed in the first column:

- ✓ OK: The last readout was successful.
- ⚠ Device error: An error was reported to the SIN.EQRTUEVO2T via M-Bus.
- ⚠ Communications error: No communications with the device.

You can navigate through the list with the and navigation buttons. Press **OK** to go to the data for the selected meter.

② The first panel provides general information on the selected meter:

- SN: Serial Number: fabrication number
- PA: Primary Address
- D1: Description, designation
- LN: Line (connection): M1M2 or via serial bus ABC
- MM: Medium
- TI: Time Interval: readout frequency

③ Displays the values from the last meter readout, if available.

The ⬆️ and ⬇️ navigation buttons take you to additional meter fields for this readout time.

④ The following image explains in detail the meter configuration fields shown on the display.

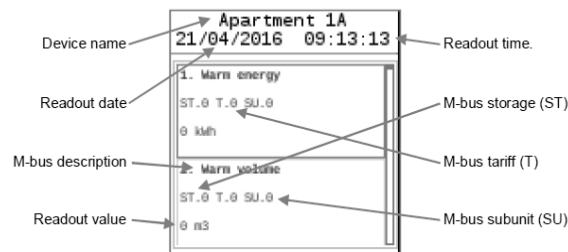

Device name	The setting is selected over web operation in the menu Settings → Wired devices → Device settings → Select the device → Data point settings
Readout date	Displays the date of the meter readout
Readout time	Displays the time of the meter readout
M-Bus description	Displays the field description as per the M-Bus protocol
M-Bus storage:	Displays the storage number of the displayed M-Bus data point. See the meter documentation for additional information
M-Bus tariff	Displays the tariff number of the displayed M-Bus data point. See the meter documentation for additional information
M-Bus subunit	Displays the number of the subunit for the M-Bus data point. See the meter documentation for additional information
Readout value	Displays the value with unit at the time of the meter readout

Important The display only displays meter fields where the option **Display data** is selected. The setting is selected over web operation in the menu **Settings → Wired devices → Device settings → Select the device → Data point settings**

7.4.3 Wired search menu

In the Wired search menu, press **OK** to start a scan for connected meters. The default search criteria:

- M-Bus line: M1M2
- Scan speed: 2400 bp
- Scan type: Secondary address

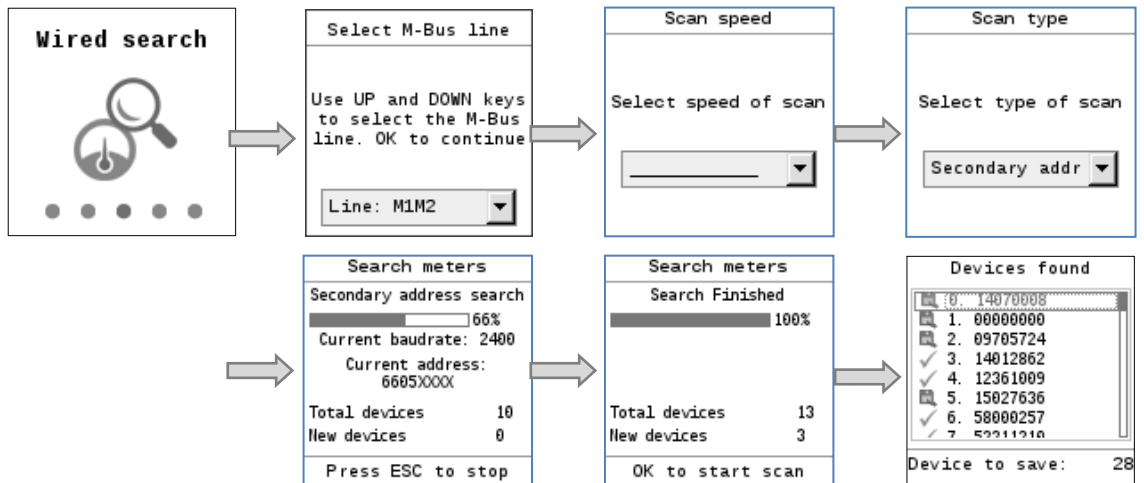

- M-Bus line Select the M-Bus line to scan for meters: via M1-M2 or via ABC
- Scan speed Select the baud rate used by SIN.EQRTUEVO2T to scan for meters: 300 bps and 2,400 bps / 300 bps / 600 bps / 1,200 bps / 2,400 bps / 4,800 bps /9,600 bps
- Scan type Select the M-Bus addressing type used in the scan: Primary + secondary address / Primary address / Secondary address

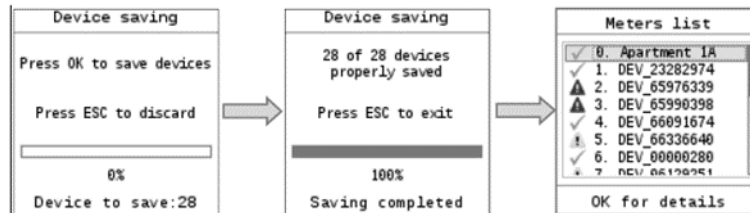

- Check meters and save A list of devices found is displayed after the meter scan is finished. Press **OK** to save all newly found meters and add them to the device list. The **ESC** button does not add the newly found meters to the device list. To edit meter settings over web operation, see menu **Settings / Wired devices/Device settings**.

7.4.4 RF search menu

Select the RF search main menu and press **OK** to start the search for RF devices.

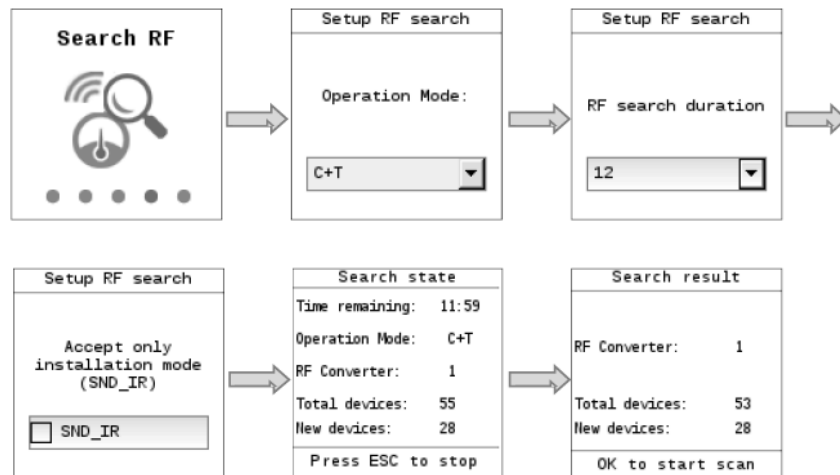

- Operation mode** Select the operation mode. Ensure that the operation mode for M-Bus is the same for both the gateway as well as the devices on the RF network. The following values are available: **S, T, C+T, C+T & S.**
- RF search duration** Select the duration of the search.
Values 1 to 24 are available.
- Installation mode** You can limit the search and only display devices in installation mode by selecting **SND_IR**: Function.

7.4.5 Settings menu

The **Settings** menu has three sub-menus:

- System
- LAN
- RF network

- You can navigate the submenus with the ◀ and ▶ navigation buttons.
- You can navigate within the submenus with the ▲ and ▼ navigation buttons.
- The OK button selects a field for editing and then confirms the entered value.

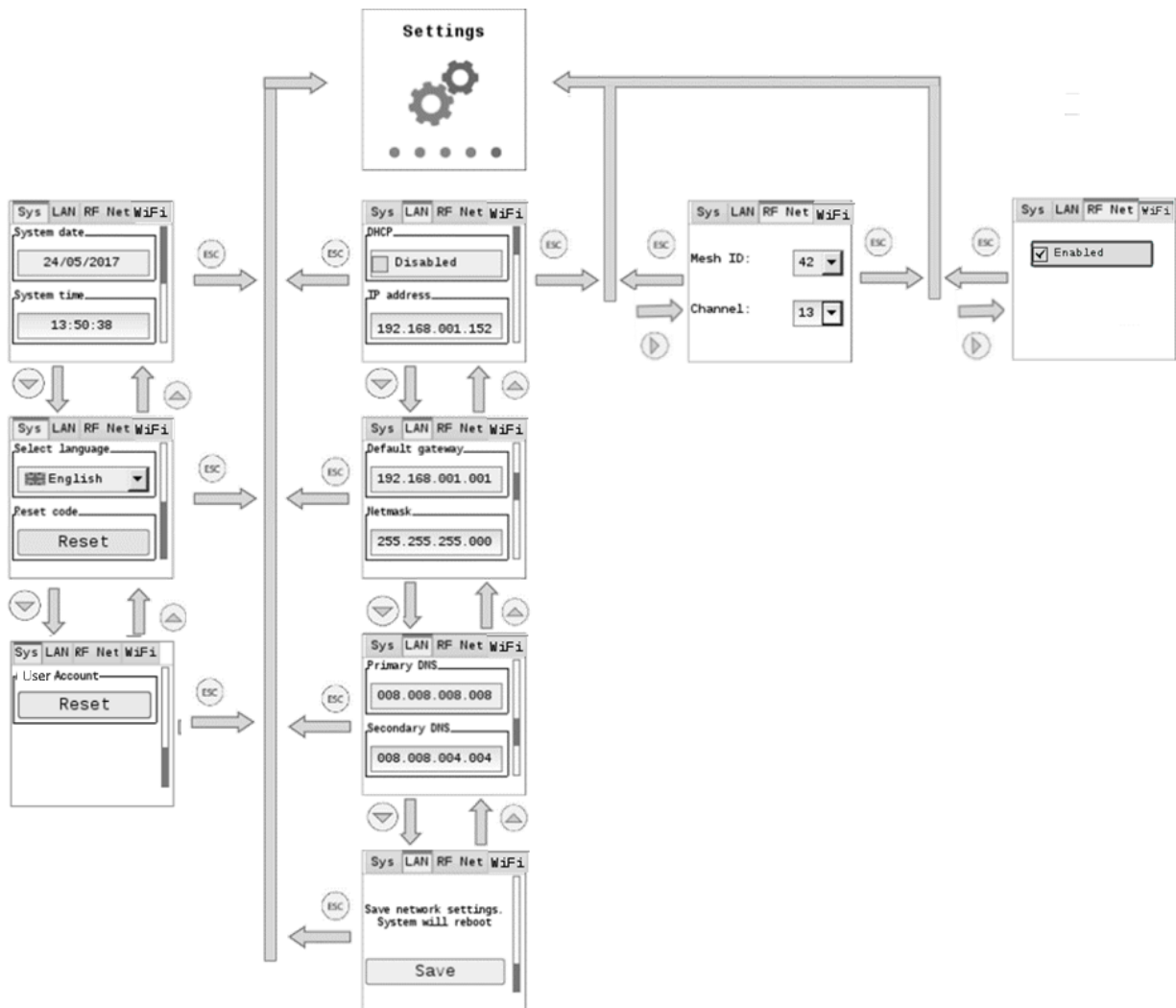

7.4.5.1 System

The **System** sub-menu has the following settings:

System date Enter the current date of the SIN.EQRTUEVO2T.

System time Enter the current time of the SIN.EQRTUEVO2T.

Select language Select the language on the SIN.EQRTUEVO2T display.

Important! The language set locally on the SIN.EQRTUEVO2T is also used for sending emails and to generate reports and alarm notifications. As a result, it is important to select the correct language during SIN.EQRTUEVO2T commissioning.

Reset code To change the current access code. You are requested to enter a new access code.

User Account Reset all previously created users. New users can be created. Leave all other settings unchanged.

7.4.5.2 LAN

The **LAN** sub-menu has the following settings:

DHCP Enable or disable the DHCP client on the SIN.EQRTUEVO2T. The SIN.EQRTUEVO2T draws its IP address automatically from the DHCP server (router) if the DHCP client is enabled.

The following parameters must be entered manually if the DHCP client is disabled:

IP address IP address of the SIN.EQRTUEVO2T. It cannot be set with DHCP enabled.
Default value: 192.168.0.110

Default gateway The standard gateway represents the interface between the local and public network. You typically enter the IP address for the router here. Need not be set if the DHCP is enabled.
Default value: 192.168.1.1

Network mask The IP subnet mask sets the size of the network. Need not be set if the DHCP is enabled.
Default value: 255.255.255.0

Primary DNS The DNS name server (domain name system) on the Internet connects a globally valid name to a domain with an IP address (e.g. domain www.xxxxxxx.com with IP address 146.254.191.150). The setting corresponds to the IP address for the next router or DNS name server that recognizes for its part a queried name (domain) or another DNS name server. The setting is typically identical to the setting for the standard Gateway. Need not be set for "DHCP = Enabled" If the DHCP settings are deactivated, please contact your local administrator for the specification of the parameters.
Default value DNS1: 8.8.8.8

Secondary DNS A secondary DNS name server is only defined for redundant systems. Settings are typically empty. Need not be set if the DHCP is enabled.
Default value DNS2: 8.8.4.4

Save The current network settings are saved and SIN.EQRTUEVO2T restarts.

7.4.5.3 RF network

You can set the following In the RF network submenu:

Mesh ID Enter the mesh ID. Ensure that all gateways are on the same mesh network.

Channel Mesh network channel: You can change the channel ID here in the event of faults.

7.4.5.4 Wi-Fi

In the Wi-Fi submenu you can turn Wi-Fi on or off.

8. SIN.EQRTUEVO2T BROWSER OPERATION

8.1. Registration and access, activation of Web Access service

The datalogger and the PC are connected to the same network and the network must be correctly configured. **See section 6.1 Connect SIN.EQRTUEVO2T to PC or LAN.**

The **Web Access** service of Sinapsi allows all users to reach the SIN.EQRTUEVO2T wherever it is in the world, as if it were connected via LAN, in order to activate it you must register to our portal following the instructions in the section below 8.1.2 **Registration and access, activation of Web Access service**. For further information on the functioning of this service please refer to the **9.3 Web Access** appendix.

8.1.1 Initial registration

To access datalogger, enter the datalogger IP address (e.g. https://192.168.1.110) in the browser (Chrome, Edge, Safari, Firefox).

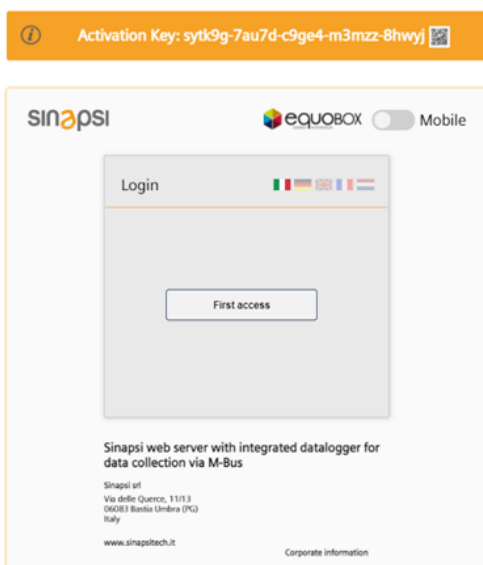

It is possible to display the webserver interface in mobile mode. This makes it possible to adapt the contents of the page to the screen of a smartphone type device.

Switch the button from:



to:



Complete the mandatory fields to register and receive access to the datalogger:

- Email
- Username
- Password
- Confirm password

The password must meet the following conditions:

- At least 8 characters
- Three of the following 4 criteria must be fulfilled:
 - Lowercase letters
 - Uppercase letters
 - A digit
 - A special character

Important The register button is only enabled after meeting the password conditions.

Sign in

You are notified if you enter an incorrect login or password. The login is locked on the datalogger for five minutes (300 s) after a maximum of six attempts.

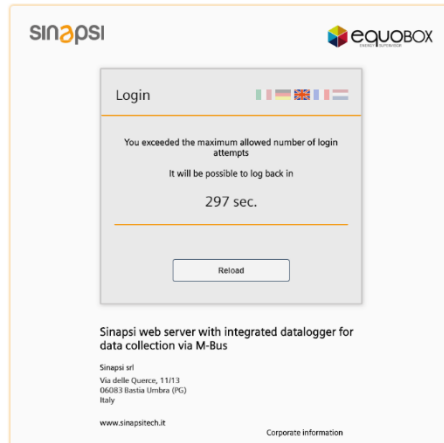

Contact the administrator if the user or maintainer forgets the access data. The administrator can delete the current account and set up a new one.

Very important

Loss of administrator password:

For security reasons if the administrator loses the access data, he needs to contact the customer service of Sinapsi via email at service@sinapsitech.it to restore the password!

Sign in

Datalogger goes to the Login page after successful registration. You can now log in using the new username and password.

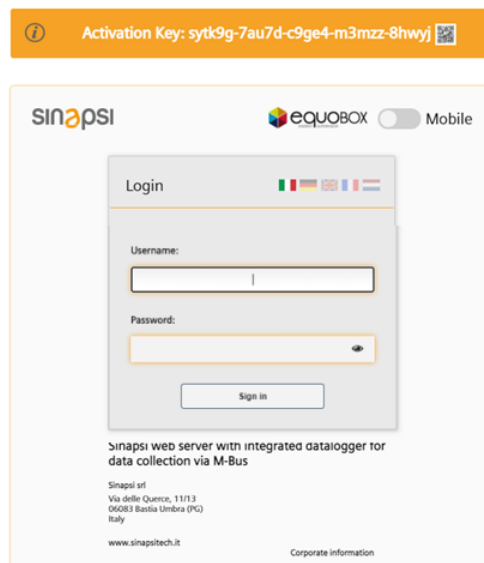

8.1.2 Access Service Activation

The service requires activation. Activation can be performed by the user in four ways:

1. Using the QR code on the side of the device



The user scans the QR code with a common smartphone. The scan leads him to the internet address <https://app.sghiot.com/mysinapsi/#!/activation>.

Activation Key del tuo device

XXXXXX - XXXXX - XXXXX - XXXXX

sinapsi

Utilizza il tuo account MySinapsi

Email - Il tuo account MySinapsi *

Valore richiesto.

Password *

Valore richiesto.

Avanti

Registrati se non hai un MySinapsi Account

Italiano

At this point the user, in case of first activation of the service, will have to register following the instructions. After successful registration, the Web Access service is enabled.

Note: To have the service actually running, it is necessary to wait about twenty minutes after activation.

2. Clicking on the image of the barcode from the "First access" or "Login" page (in case you have already created a user), to view it scan it with your smartphone:

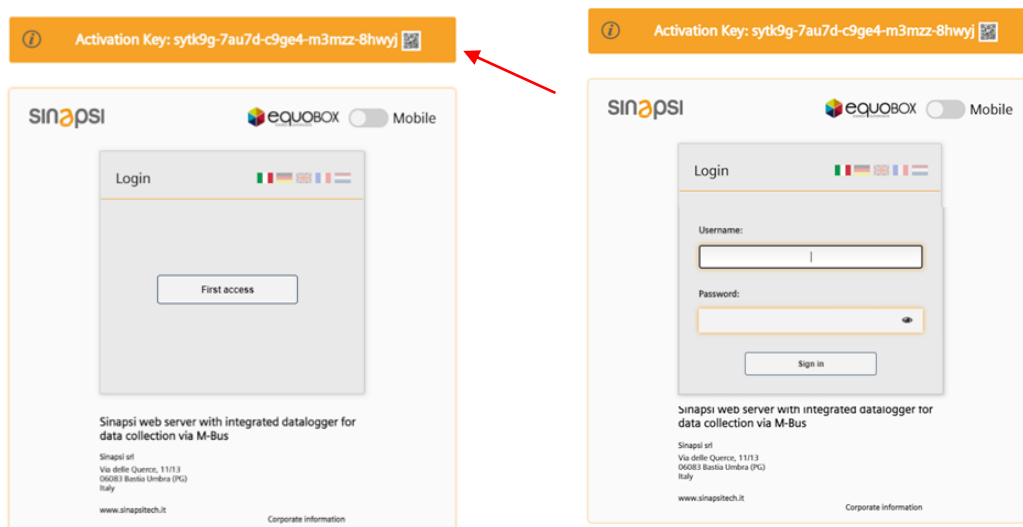

The scan then leads to the internet address <https://app.sghiot.com/mysinapsi/#!/activation>.

Subsequent steps remain unchanged from the previous point.

3. Manually entering the activation key (21-digit number / XXXXXX-XXXXX-XXXXX-XXXXX) on the label on the side of the SIN.EQRTUEVO2T device, near the QR code, at <https://app.sghiot.com/mysinapsi/#!/activation> .

Subsequent operations remain unchanged from step 1.

4. Activation from Web interface:

Any SIN.EQRTUEVO2T for which the Web Access service (also referred to as the "reachability service") is activated will be reachable at:

<https://ev<serial number>.net.sghiot.com>

Where <serial-number> is the serial number of the device (consisting of eight digits).

For subsequent activations (other similar SIN.EQRTUEVO2T devices), it will be sufficient to scan the QR code and click on "Next" (provided that you have saved the credentials through the browser used).

Important

To use this service, you need to check if inbound and outbound communication is allowed on port 1194 with UDP protocol.

8.2. Home

- 1 The following information is displayed on the title line:
 - Name of the logged in user.
 - Language selection.
 -  Information on "Open source software" packets and licenses.
- 2 Primary navigation using the main menus:
 - Plant status
 - Settings
 - Export data
 - User account
- 3 Status Information:
 - M-Bus status

- Status M-Bus radio
- Number of logged on users
- Date and time.

4 Secondary navigation using sub-menus

5 Information on menu and sub-menu page

8.2.1 Select the datalogger language

You can set the operating language for the software interface in the title line to the right.

The following languages are available:

- English
- German
- Italian
- French
- Dutch

Important!

The default language used on the login is selected and displayed on the display of the datalogger. The language setting in the login window applies exclusively to the current session. The language setting on the datalogger software interface apply exclusively for the current session after login.

All automatic reports use the default language. Select **default operating language**.

All manual reports created on the datalogger use the language for the current session.

8.3. Plant status

The Plant status main menu displays all important information on the datalogger, connected devices, and events occurring on the bus.

8.3.1 System status

System status displays system information, the event log and status information of SGH NET.

8.3.1.1 System Information

The screenshot shows the SINAPSI web interface. The top navigation bar includes the EQUOBOX logo on the left and the SINAPSI logo on the right. Below the navigation bar, there is a user profile section for 'Steve Jobs' and a language dropdown menu set to 'English'. The main content area is titled 'System info' and contains three tabs: 'System info', 'Event log', and 'Web access'. The 'System info' tab is active, showing a 'General status' section with the following information:

Internet connection : OK	Plant name : Sinapsi RTUEVO1T Demo 170
Current IP address : 185.20.64.226	Serial number : EV16000193
Web access status : ● Reachable	Model : SIN.EQRTUEVO1T
Wi-Fi status : ● Not active	Address : Via delle Querce 11/13
Wi-Fi : <input type="button" value="Enable"/>	Firmware version : 4.9_2.0_3.1
	Web interface version : 3.40

At the bottom left of the interface, there is a system status panel showing 'Idle', 'Idle', '1' users, and the date/time '27/08/2021 15:54'.

The following information is available under System Status:

- Connection: displays the current status of the web server's Internet connection.
- Current Public IP: displays the last public IP address of the datalogger.
- Status Web Access: displays the service status between online, offline, inactive
- Wi-Fi Status: displays the status of the Wi-Fi connection
 - Inactive
 - Enabled: remaining time, SSID, Wi-Fi Address, MAC Address

Wi-Fi: Button to enable or disable Wi-Fi of the datalogger

- Plant name: name of the plant.
- Serial number: display the datalogger serial number.
- Model: displays the designation of the type of web server.
- Address: plant location.
- Firmware Revision: displays the firmware version installed on the Web server.
- Web Interface Revision: displays the installed version of the Web user interface.

8.3.1.2 Event log

#	Type	Start date	End date	Category	Reference	Description	Select
	⚠	2020-06-16 13:11:44	-	Meter	RF DEV_55635610	meter_alarm_mappower_low	<input type="checkbox"/>
	⚠	2020-05-18 00:00:30	-	Meter	RF DEV_61006100	meter_alarm_mappower_low	<input type="checkbox"/>
	⚠	2020-05-15 12:33:18	2020-05-18 11:03:53	Meter	RF DEV_00012197	Generic error	<input type="checkbox"/>
	✔	2020-05-15 12:33:18	2020-05-18 11:03:53	Meter	RF DEV_00012197	Alarm intern magnet	<input type="checkbox"/>
	✔	2020-01-28 09:46:16	2020-01-28 11:45:25	Meter	RF DEV_00012197	Generic error	<input type="checkbox"/>
	✔	2020-01-28 09:46:16	2020-01-28 11:45:25	Meter	RF DEV_00012197	Alarm intern magnet	<input type="checkbox"/>
	⚠	2020-01-20 12:55:15	-	Meter	RF DEV_00012197	Fraud error	<input type="checkbox"/>
	⚠	2020-01-20 12:55:15	-	Meter	RF DEV_00012197	Fraud	<input type="checkbox"/>
	⚠	2020-01-20 12:54:55	-	Meter	RF DEV_68262279	Temporary error	<input type="checkbox"/>
	✔	2020-01-20 12:54:24	2020-04-08 12:46:00	Meter	RF DEV_61006100	meter_alarm_mappower_low	<input type="checkbox"/>
	⚠	2020-01-20 12:54:24	-	Meter	RF DEV_68431626	Flag bit 4	<input type="checkbox"/>
	✔	2020-01-20 12:54:16	2020-01-31 12:04:59	Meter	RF DEV_00011882	meter_alarm_mappower_low	<input type="checkbox"/>
	⚠	2020-01-20 12:53:25	-	Meter	RF DEV_64113135	Permanent error	<input type="checkbox"/>
	⚠	2020-01-01 00:01:29	-	Meter	NA DEV_66660211	Communication error	<input type="checkbox"/>
	⚠	2019-12-19 12:01:00	-	Meter	NA DEV_10485501	Communication error	<input type="checkbox"/>
	⚠	2019-12-19 12:00:46	-	Meter	NA DEV_10485502	Communication error	<input type="checkbox"/>

The event log records the following events:

- Alarms and warnings
- Change of state of inputs/outputs
- Send status of emails
- Send status of information via FTP

The following information can be read by event:

- Type
- Start date/time
- End date/time
- Category
- Reference
- Description

The following event status can be displayed:

- ✔ Device OK: Reported alarms or warnings are correct.
- ⚠ Device fault: A device fault reported via M-Bus.
- ⚠ Communications error: Communication with M-Bus device not possible.
- ✔ Email successfully sent.
- ✉ The email could not be sent (over 3 days at 15 minutes intervals, not successful).
- FTP The readout file was successfully transmitted to an FTP server.

- FTP The readout file was unable to be transmitted to an FTP server (over 3 days at 15 minute intervals, unsuccessful).
- IN Change of state registered at an input.
- OUT Change of state registered at an output.

Simply set filters for each column to limit search results by specific events.
The event log registers up to 1000 events. The oldest event is removed after 1000 events.
Individual lines on the event log or the entire list can be deleted.

Proceed as follows:

- Delete individual rows: Select the event check box to be deleted and then click **Delete event** in the upper end of the list. The **Delete event** is enabled if at least one line is selected.
- Delete complete list: Select the check box on the title line and then **Delete event** to irretrievably delete the entire event log.

Note **Display only active events** to list only currently pending alarms and input/output status.

Click a line to display event details, e.g. the sent email including appendix and the last readout data just prior to the fault.

The screenshot displays the EQUOBOX SINAPS I web interface. The top navigation bar includes the EQUOBOX logo, the user name 'Mario Rossi', and the SINAPS I logo. The main content area is divided into a left sidebar with navigation options (Plant status, System status, Wired devices, Wireless devices, Inputs/Outputs, Settings, Export data, User account) and a central event log table. The event log table has columns for Type, Start date, End date, Category, Reference, and Description. A specific event is highlighted, and its details are shown in a form below the table. The details form includes fields for Device name, Scan interval, Description 1, Install date, Description 2, Primary address, ID Device, and Manufacturer code. A 'Last readout timestamp' is also displayed. The event log table shows several events, including 'Fraud error', 'meter_alarm_map|power_low', and 'Generic error'.

#	Type	Start date	End date	Category	Reference	Description	Select
		No Filter ...	No Filter ...	No Filter ...	No Filter ...	No Filter ...	
	⚠	2020-07-02 12:47:36	-	Meter	RF DEV_00012199	Fraud error	<input type="checkbox"/>
	⚠	2020-06-16 13:11:44	-	Meter	RF DEV_05635610	meter_alarm_map power_low	<input type="checkbox"/>
	⚠	2020-05-18 00:00:30	-	Meter	RF DEV_61006100	meter_alarm_map power_low	<input type="checkbox"/>
	✓	2020-05-15 12:33:18	2020-05-18 11:03:53	Meter	RF DEV_00012197	Generic error	<input checked="" type="checkbox"/>
	✓	2020-05-15 12:33:18	2020-05-18 11:03:53	Meter	RF DEV_00012197	Alarm intern magnet	<input type="checkbox"/>
	✓	2020-01-28 09:46:16	2020-01-28 11:45:25	Meter	RF DEV_00012197	Generic error	<input type="checkbox"/>
	✓	2020-01-28 09:46:16	2020-01-28 11:45:25	Meter	RF DEV_00012197	Alarm intern magnet	<input type="checkbox"/>
	⚠	2020-01-20 12:55:15	-	Meter	RF DEV_00012197	Fraud error	<input type="checkbox"/>
	⚠	2020-01-20 12:55:15	-	Meter	RF DEV_00012197	Fraud	<input type="checkbox"/>

8.3.1.3 Web Access

As mentioned in the previous chapters, Web Access is a service that allows all users to reach the SIN.EQRTUEVO2T wherever it is in the world as if it were connected via LAN.

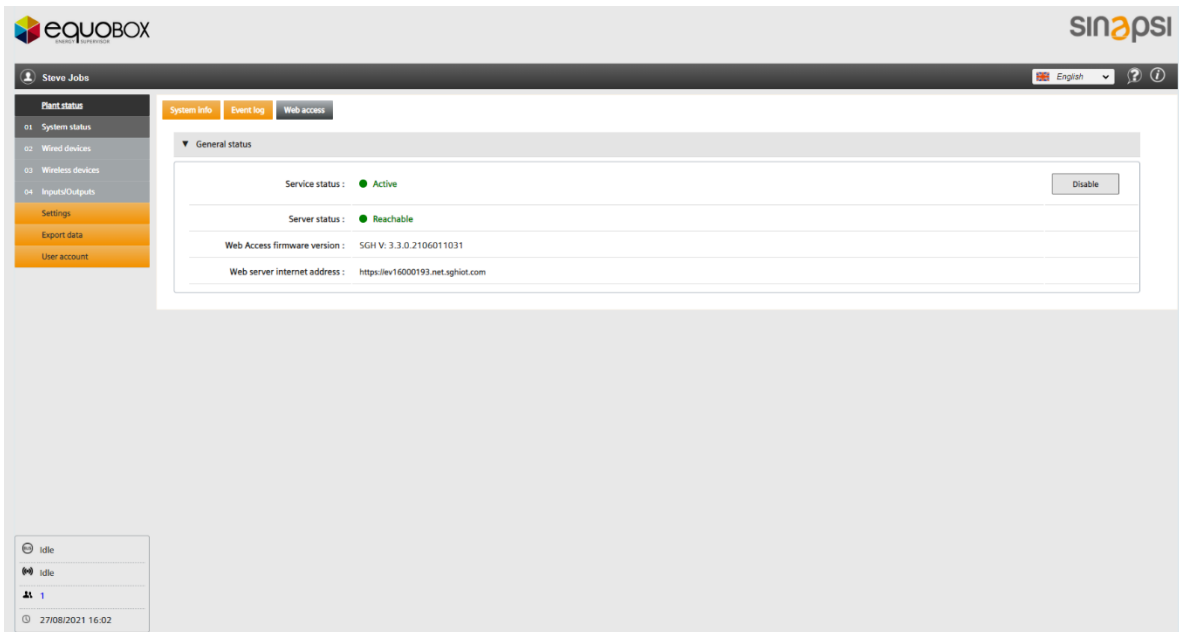

The following information is available in the general status of Web

- | | |
|---------------------------|--|
| Service activation: | You can enable or disable the service |
| Service status: | It shows if the service is online or not |
| Service firmware version: | The firmware version of the Web Access service of the datalogger is displayed. |
| Indirizzo Internet: | The Internet address to reach the datalogger SIN.EQRTUEVO2T. Click on the address or type it in the address bar of your browser to connect to the SIN.EQRTUEVO2T using the Web Access service. |

8.3.2 Wired devices

The Wired devices overview lists all M-Bus devices located on the network in an abbreviated form.

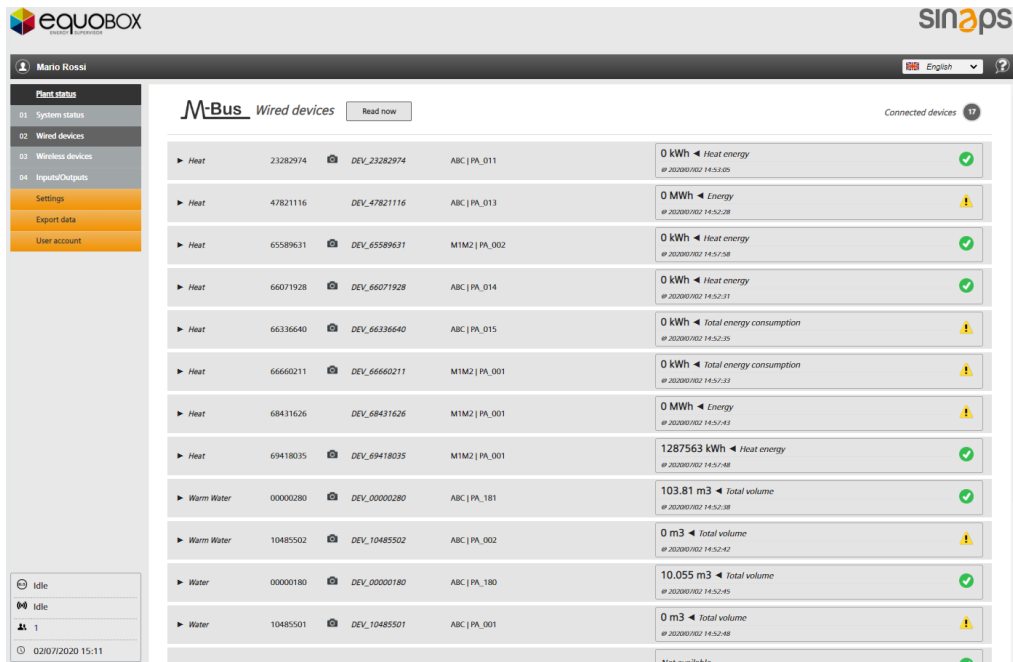

The following information can be read out per line (per M-Bus device):

- Medium
- Serial number (secondary address)
- Availability of device image
- Device Name (By default it's DEV_serial)
- Description: the bus where the meter is connected (M1M2 or ABC) and description
- Main value (=> Can be selected, see Section "Settings→Wired devices")
- Last readout timestamp
- Device state

The following device status can be displayed:

- ✔ Device ok
- ⚠ Device fault
- ⚠ Communication error

Click a line to list additional device information

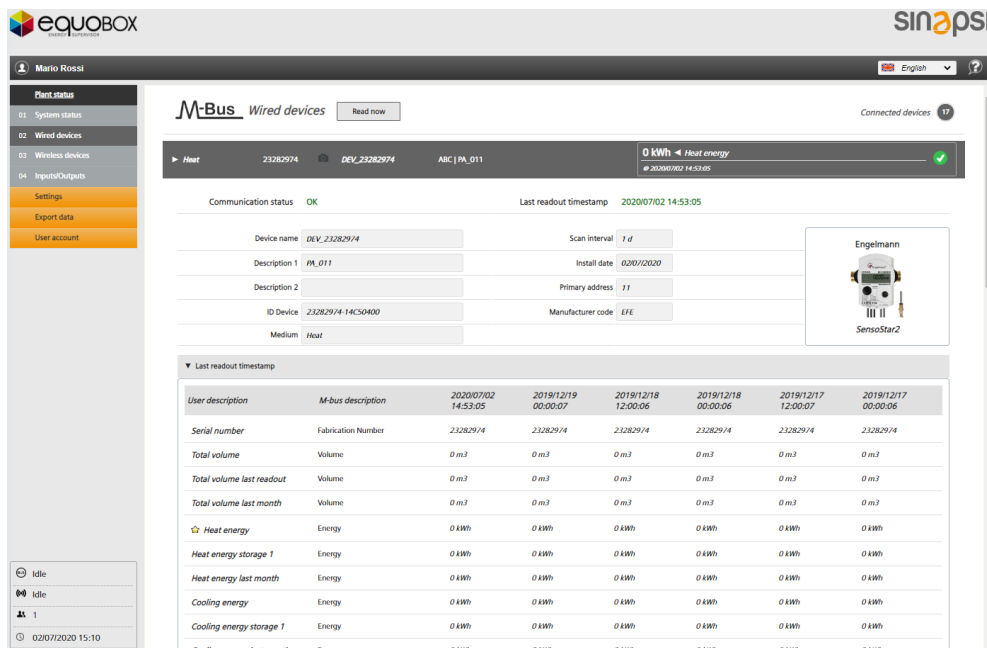

The information is grouped into three categories:

- Device information: General device data (name, description, ID, medium, etc.)
- Last readout timestamp: Displays the values of the last 6 readouts.
- Alarm status: Shows the faults on the device and which ones are registered, sent via email, the event type and the status.

The data points for display in detail, can be predefined in the menu **Settings / Wired devices / Device settings**.

Click **Read now** to manually trigger a complete readout of the data from all devices.

8.3.3 Wireless devices

The Wireless devices overview lists all the M-Bus Wireless devices on the network in a compact form.

Device ID	Description	Status
32500781	DEV_32500781	000000 ◀ Total HCA @ 20191220 12:10:16
34584901	DEV_34584901	Not available
35026217	DEV_35026217	0.001 m3 ◀ Total volume @ 20191220 12:12:06
51110341	DEV_51110341	0 ◀ Total HCA @ 20191220 12:09:59
51110369	DEV_51110369	Not available
52211207	DEV_52211207	0 ◀ Units for H.C.A @ 20191220 12:10:21
52211210	DEV_52211210	0 ◀ Units for H.C.A @ 20191220 12:12:02
52211212	DEV_52211212	0 ◀ Units for H.C.A @ 20191220 12:09:56
52211218	DEV_52211218	0 ◀ Units for H.C.A @ 20191220 12:11:59

The following information can be read per line (i.e. per M-Bus wireless devices):

- Medium
- Serial number
- Availability of device image
- Device Name (By default it's DEV_serial)
- Description: Customized by the user (e.g. installation point)
- Main value (=> Can be selected, see Section **"Settings→Wireless devices"**)
- Last readout timestamp
- Device state: active alarm signalling
- Reception signal strength
- Serial of the RPT868XT gateway that last sent the device data.
- Date and time of last transmission of the data
- Number of gateways that receive data from the wireless M-Bus device
- Cryptographic key required to read the meter data: green → correct key, red → incorrect or not inserted key.

The following device status can be displayed:

- ✔ Device is OK
- ⚠ Device fault
- 🚫 Communication error

Click a line to list additional information on a particular device.

The screenshot displays the 'Settings' page for a device. The top navigation bar shows the user 'Mario Rossi' and the language 'English'. The left sidebar is active on 'Inputs/Outputs'. The main content area shows the following details:

- Device name:** DEV_69399801
- Scan interval:** 12 hrs
- Description 1:** (empty field)
- Install date:** 2018-03-02 1.
- Description 2:** (empty field)
- Manufacturer code:** LUG
- ID Device:** 69399801
- Wireless M-Bus mode:** C+T
- Medium:** Heat
- Encryption:** Mode 5
- Encryption key:** ***** Correct key

A table titled 'Last readout timestamp' provides the following data:

User description	M-bus description	2019/12/20 12:10:01	2019/12/20 06:13:32	2019/12/19 12:01:15	2019/12/19 00:01:57	2019/12/18 17:33:09	2018/06/21 14:09:13
★ Total energy consumption	Energy	13850 kWh	13850 kWh	13850 kWh	13850 kWh	13850 kWh	13850 kWh
Total volume	Volume	404.47 m ³	404.47 m ³	404.47 m ³	404.47 m ³	404.47 m ³	404.47 m ³

The information is grouped into three categories:

- Device information: General device information (Name, description, ID, medium, polling interval, installation date, manufacturer code, RF mode, encryption, etc.)
- Last read out timestamp: Displays the values of the last 6 read outs.
- Alarm state: Shows the faults on the device and which ones are registered, sent via email, the event type and the status.

8.3.4 Inputs/Outputs

Displays the current status (open/closed) of inputs/outputs on datalogger.

The screenshot displays the 'Inputs/Outputs' page. The left sidebar is active on 'Inputs/Outputs'. The main content area shows the following details:

- Digital Inputs (Contact status):**
 - I1: Open
 - I2: Open
 - I3: Open
- Digital Outputs (Contact status):**
 - O1: Open
 - O2: Open

The following information can be read by input/output:

- Image of connection terminals on datalogger
- Short description: I = Input, O = Output
- Status: Open/closed
- Designation

Click **Switch** to manually switch the digital outputs (available for the user type "Administrator").

8.4. Settings

8.4.1 System

8.4.1.1 Plant data

The following plant data can be assigned to datalogger:

- Plant name
- Address
- Installer name
- Customer name
- Install date (the current date by default)

Note The edited data must be confirmed with **Save**.

The plant name and address are displayed on the home page in the lower section to easily ID the datalogger, even before logging in.

Activation Key: [a8awjs-6ffpd-z3nz3-fb9zj-j7rna](#)

Sinapsi RTUEVO1T Demo 170
Via delle Querce 11/13

8.4.1.2 Alarms

As soon as datalogger detects an alarm, it sends an alarm notification to the designated email address:

Emails are only sent if **Enable alarm notifications via email** is selected.

The alarm notification can be simultaneously sent to multiple recipients. Multiple email addresses must be separated by a semi-colon (;). The email subject line can be individually set to simplify classification in the event of multiple plants. Confirm it with **Save**.

8.4.1.3 System settings

System settings has 4 areas:

1. **System clock:** You can automatically sync the system clock with the PC or enter it manually.
2. **Report Settings:** You can select whether to use a period or a comma as the decimal separator.
3. **System restart:** You can remotely restart the datalogger pushing **Restart** button.
4. **Reset access code local display:** You can reset the access code for local access on datalogger. For security reasons, immediately change the password locally on the datalogger after a reset.

Important! The local access code cannot be entered remotely. You must visit the plant.

8.4.1.4 Maintenance

The page is used to update the datalogger firmware.

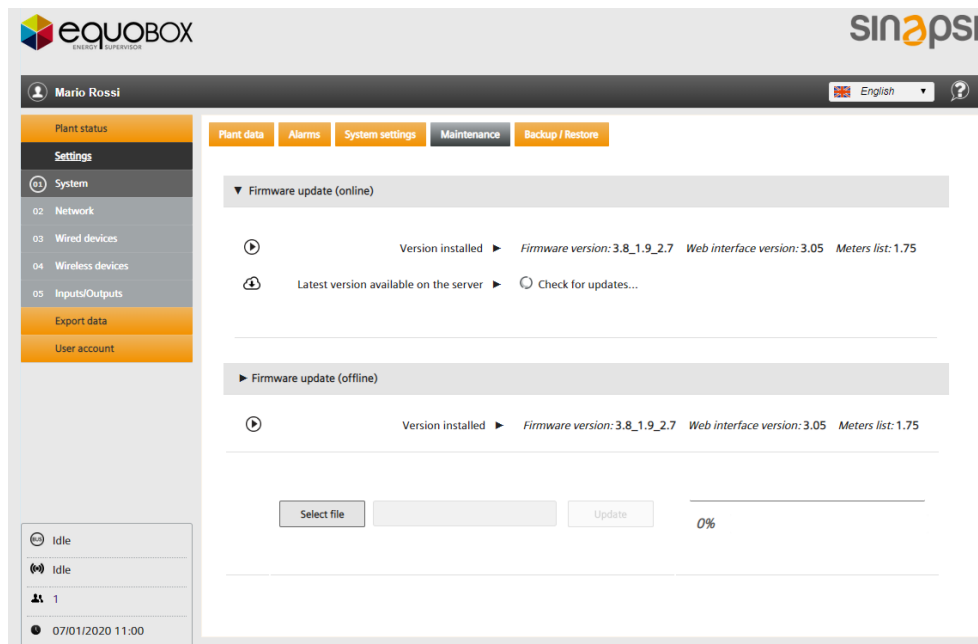

The firmware can be updated online or offline. The appropriate firmware can be installed directly from the Internet on the datalogger (online) or via PC (offline).

Datalogger restarts after updating. Install progress as well as restart is displayed.

Important! After a firmware update all data are available again. It is recommended to do a backup and to save the data on a PC before the actualization.

8.4.1.5 Backup / restore

All datalogger data is backed up and / or restored on this page.

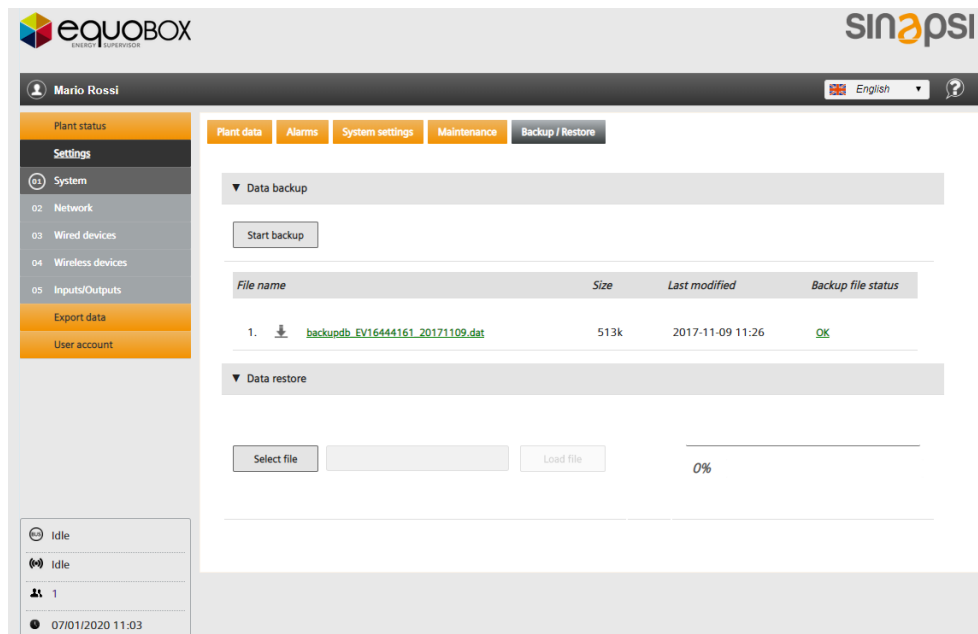

Important! We recommend regularly backing up datalogger data.

Data backup

The following information is displayed on each data backup:

- File name
- Size
- Last modified
- Backup file status

The backup file can be downloaded on a PC by clicking  or the file name and then uploaded to the same or another datalogger.

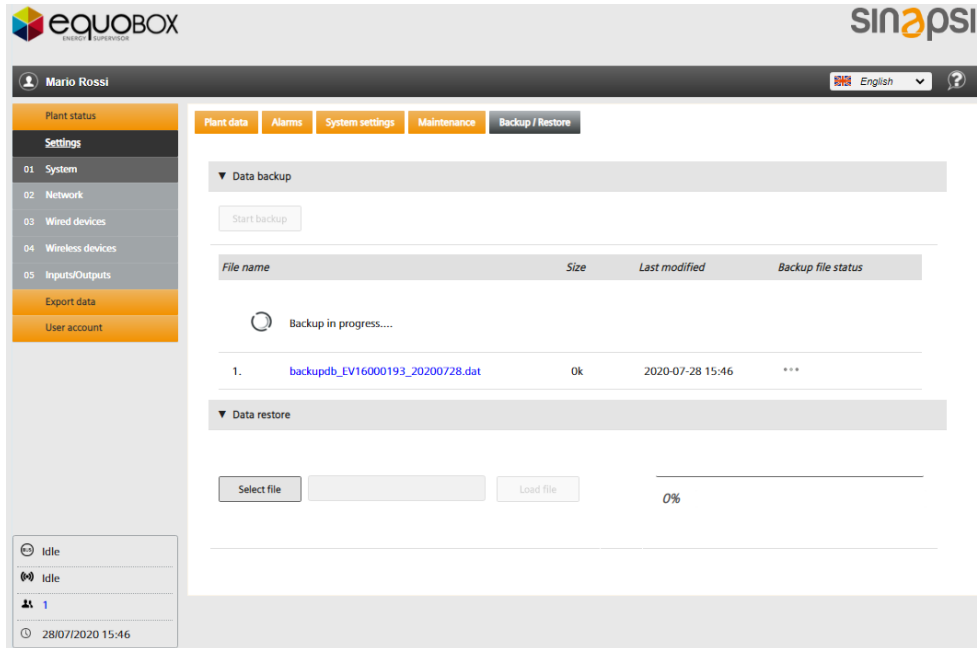

Important! Always copy backup files to your PC. This is the only way to load the backup file from a defective datalogger to a new datalogger.

Important! The backup file is encrypted. The device data cannot be altered.

Data restore

To transmit a backup file to datalogger, select the appropriate file (**Select file**) and install (**Load file**). Datalogger restarts after updating. Install progress as well as restart is displayed.

Important! This workflow irretrievably removes all data and settings on the current datalogger. As a result, we recommend conducting a backup of the current data prior to storing.

8.4.2 Network

8.4.2.1 Network settings

The following information and settings are available:

- Datalogger MAC address.
- External port for datalogger: This is only an information of the external port used by the SIN.EQRTUEVO2T. This external port number must be the same in the port forwarding settings of the router.
- Enable DHCP for the DHCP server (router) to automatically assign the IP address.
- Datalogger IP address if a fixed IP address is assigned.
- Network mask.
- Gateway IP address: IP address for the standard gateway (e.g. Router).
- Primary DNS: The primary DNS name server (Domain Name System) address
- Secondary DNS: Secondary DNS name server address

Click **Save** to confirm changes to the above parameters.

Important! Be careful when changing these settings! Ask your local network administrator for the required data on network configuration.

Datalogger is not suitable for connecting directly to the Internet; it must be connected via a modem. This type of router typically has a firewall.

8.4.2.2 Email configuration

The following data of your mail server must be entered for forwarding emails:

The screenshot shows the EQUOBOX web interface for email configuration. The user is logged in as Mario Rossi. The interface is divided into a left sidebar with navigation options (Plant status, Settings, System, Network, Wired devices, Wireless devices, Inputs/Outputs, Export data, User account) and a main content area. The main content area has tabs for Network settings, Email setup, and Dynamic DNS. The 'Email setup' tab is active, showing the 'Email server settings' section. The settings are as follows:

- SMTP server name: smtp.sinapsitech.it
- SMTP port: 25
- SMTP security: NO
- SMTP authentication:
- SMTP user name: test
- SMTP password: [masked]
- Sender name: Test PROVA sender
- Sender email address: prova@test.it

Below the settings is a 'Save' button. The 'Server connection test' section is also visible, with a text input field for the recipient's email address and a 'Server connection test' button.

Email server settings

The following email server settings are available:

- SMTP server name: the address for the SMTP server.
- SMTP port: the port number used by the SMTP server.
- SMTP security: selection of either SSL or TLS security. The setting NO sends the emails without encryption; do not use this setting for security reasons.
- SMTP authentication: enter whether the SMTP server requires authentication.
- SMTP username: username for accessing the SMTP server.
- SMTP password: password for accessing the SMTP server.
- Sender name: sender's name that appears in the email address (if your SMTP server allows it).
- Sender email address: the sender's personalized email address (if your SMTP server allows it).

Important! Be careful when changing these settings! Check with your email provider for the required email server settings.

Click **Save** to confirm changes to the above parameters.

Email server connection test

Clicking **Server connection test**, you can check the connection to the e-mail server by sending a report to an e-mail address of your choice.

The results are displayed as soon as the message is sent:

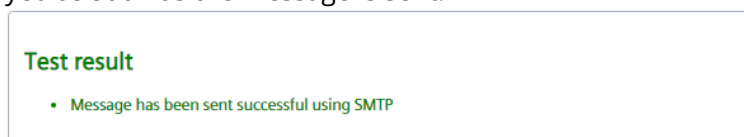

8.4.2.3 Dynamic DNS

Dynamic DNS or DDNS is a service that allows you to always associate a DNS name with the same public IP address as a host.

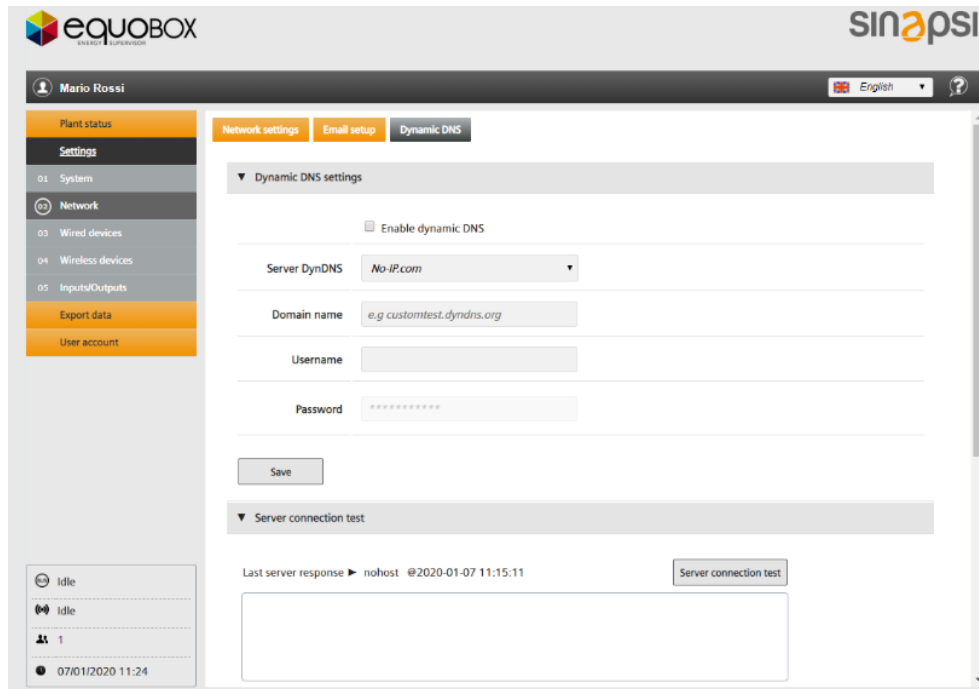

Important! You must first set up an account at the provider to use the DynDNS or No-IP server.

Dynamic DNS settings

The datalogger must inform the service of changes to the dynamic IP address for the datalogger to communicate via the setup DynDNS service. The Dynamic DNS must be set on the datalogger as follows:

- Enable Dynamic DNS settings: Allows datalogger to use a dynamic DNS service
- Server DynDNS: The following two Dynamic DNS providers are available:
 - No-IP.com
 - DynDNS.com
- Domain name: Name provided to you by your dynamic DNS supplier.
- Username: Username for accessing the dynamic DNS server
- Password: Password for accessing the dynamic DNS server

Important! Be careful when changing these settings! Ask your network administrator for the required data on network configuration.

Click **Save** to confirm changes to the above parameters.

Server connection test

You can test the connection to the DynDNS server.

The results are displayed



8.4.3 Wired devices

8.4.3.1 Devices settings

In this panel, you have access to the device list and can change settings.



Note The list is empty if no device search has been run. The devices that are found and saved are displayed on the list after a device search.

The display is structured as follow:

1. List of all the saved meters found on the M-Bus lines connected in ABC or on the M1M2 line
2. Selected counter settings
3. Data points settings
4. Meter alarm settings

1. Saved meters list

Medium	M-Bus line	Serial number	Device name	Description	Manufacturer / Model	Scan interval	
Heat	M1M2	65589631	DEV_65589631	PA_002	Siemens WFN532	1 month	
Cooling energy	M1M2	65589632	DEV_65589632	PA_003	Siemens WFN532	1 month	
Heat	ABC	66071928	DEV_66071928	PA_014	Qundis QHeat5	1 day	
Heat	ABC	66336640	DEV_66336640	PA_015	Siemens 2WR6	1 month	
Heat	M1M2	66660211	DEV_66660211	PA_001	Siemens WSM515	1 month	

- **Medium:** Display the medium
- **M-Bus line:** Displays from which line between ABC or M1M2 the saved meter was detected
- **Serial number:** Displays the meter serial number
- **Device name:** Displays the meter name as entered under device name
- **Description:** Displays the text entered under Description 1
-  : Indicates that a product image is available for the device
- **Manufacturer / Model:** Displays the 3-letter code of the manufacturer of the device if it is not already integrated in the "Presetting meter list" (meter readable but not preconfigured for reports). Otherwise it shows the full Manufacturer and the model of the M-Bus device.
- **Scan Interval:** Indicates the frequency with which the datalogger automatically interrogates the M-Bus meter to receive data.
-  **Trend Report:** Indicates if the device has configured at least one datapoint so that it is included in the "Trend Report".
- **Delete:** Click the trash can to delete the device from the list.

The list of wired devices can be exported as an .xls or .csv file. Click the corresponding symbol:



Serial number	Device name (X)	Description (X)	Manufacturer code	Medium	M-Bus line
6129250	DEV_06129250	PA_000	SMC	Water	M1M2
6129251	DEV_06129251	PA_000	SMC	Warm Water	M1M2
7964864	DEV_07964864	PA_000	LSE	Heat/Cooling	M1M2
10485501	DEV_10485501	PA_001	REL	Water	M1M2
10485502	DEV_10485502	PA_002	REL	Warm Water	M1M2
15550082	DEV_15550082	PA_000	MAD	Water	M1M2
23282974	DEV_23282974	PA_000	EFE	Heat	M1M2
66091674	DEV_66091674	PA_157	LUG	Heat	M1M2
66336640	DEV_66336640	PA_003	LUG	Heat	M1M2

2. Device settings

Click the device line to view the setting for the device

Device name	<input type="text" value="DEV_66336640"/>	(**) Scan interval	<input type="text" value="1 month"/>	
Description 1	<input type="text" value="PA_003"/>	Install date	<input type="text" value="07/07/2017"/>	
Description 2	<input type="text" value=""/>	Primary address	<input type="text" value="3"/>	
ID Device	<input type="text" value="66336640"/>	Baudrate	<input type="text" value="2400"/>	
Read by	<input type="text" value="Secondary address"/>	Manufacturer code	<input type="text" value="LUG"/>	
Medium	<input type="text" value="Heat"/>	Version (HEX)	<input type="text" value="03"/>	

Free text settings:

- Device name: You can assign a name to the device (e.g. Apartment 123).
- Description 1: Device description as indicated in the device list.
- Description 2: Additional description
- Scan interval: 15 min. / 60 min., 6 h, 12 h, 1 day, 7 days, 1 month
- Install date: You can add an installation date
- The device image can be set by clicking the  as needed. You can select the appropriate image from the datalogger device database.

Click **Save** to save the edited values.

Settings that cannot be changed:

- ID Device: Displays the device serial number
- Read by: Displays whether the meter is read via the primary or secondary address.
- Medium: Displays the medium measured by the device.
- Primary address: Displays the device's primary address (1...250)
- Baud rate: Displays the transmission rate between the device and datalogger.
- Manufacturer code: Displays the manufacturer's code.
- Version (HEX): Displays the device version.

3. Data Points settings

The screenshot shows the 'Data Points settings' section of the EQUOBOX interface. It features a table with the following columns: Main Value, User description, M-Bus description, Standard Report - Data point mapping, Custom Report - Data point to be included, and a three-dot menu. The table lists various data points such as 'Flow measure interval', 'Total energy consumption', 'Total volume', 'Current power', 'Flowrate', 'Flow temperature', 'Return temperature', 'Temperature difference', 'Total volume last year', 'Total energy last year', 'Serial number', 'Operating time', 'Error on time', 'Error on time last year', 'Due date and time', 'Energy 1 historical 1', 'Energy 2 previous month', and 'Energy 3 previous month'. A red circle with the number 3 is placed over the 'Data Points settings' header.

- Main Value: You can select the value for display on the **Plant status**→**Wired devices** overview
- User description: The data point designation can be edited
- M-Bus description: Designation of the data point according to the M-Bus specification
- Standard report – Data point mapping: Assigns data points to predefined columns on the standard report. Only one data point can be assigned to a specific column for each device. Data points with the "none" settings are not displayed in the standard report
- *Custom Report – Data point to be included*: select the data points to be included in the custom report. This report includes only the data points selected in the relevant column.
- *Trend Report – Data point to be included*: select the data points to include in the trend report. This report includes only the data points selected in the relevant column.
- "...": Click the "..." column to display additional details (Multiplier, Storage, Subunit, Tariff, Type value und Units) on the selected data point. The details can help you come up with a meaningful user description.

Main Value	User description	M-Bus description	Standard Report - Data point mapping	Custom Report - Data point to be included	...
<input checked="" type="radio"/>	Total energy consumption	Energy	hea_energy	<input checked="" type="checkbox"/>	...
Multiplier	1				
Storage	0				
Subunit	0				
Tariff	0				
Type value	Instantaneous Value				
Units	kWh				

Click **Save** to save the edited settings.

4. Alarm settings meters

For each device it is possible to display a series of error messages which are available via M-Bus.

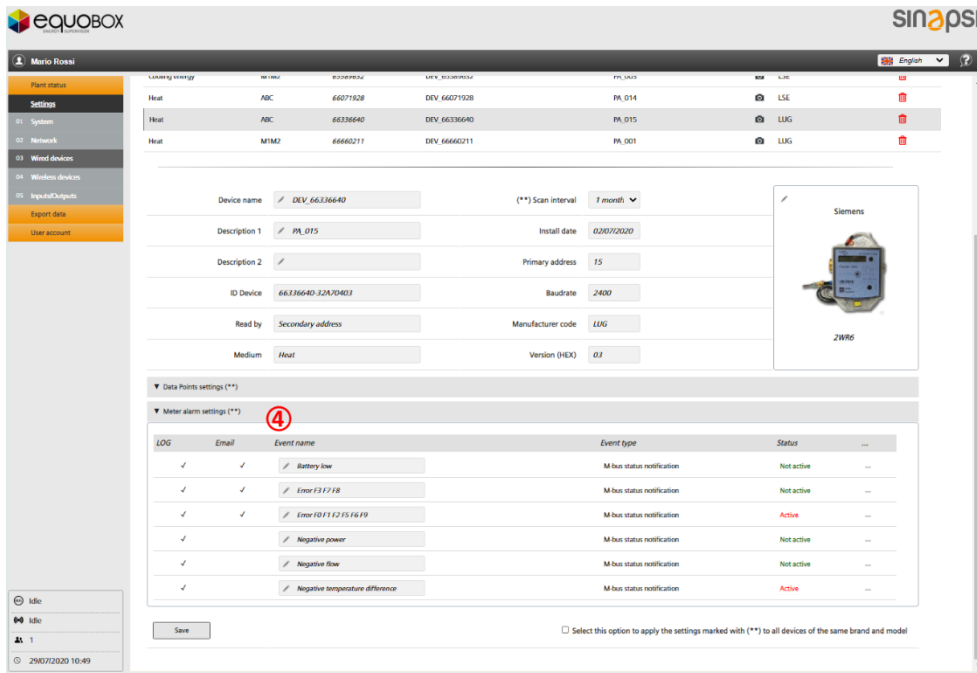

The following information and settings are available.

- LOG: When an error occurs, displays whether the message is logged in the event log.
- Email: When an error occurs, displays whether an email is sent with the error message.
- Event name: The event name is predefined. It can, however, be changed as needed.
- Event type: Displays the event type received from the device.
- Status: Displays whether the alarm is active or not active.

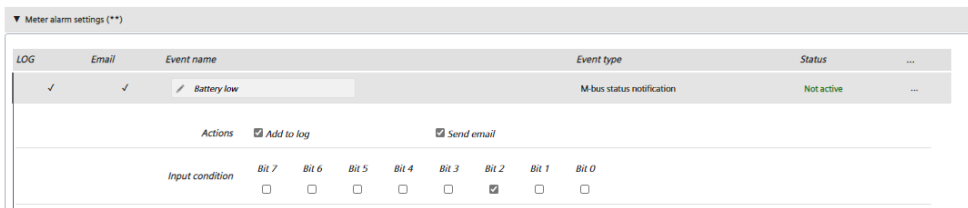

Click "... " to open a new panel with the following settings:

- Actions:
 - Add to log: Select if it is added to the event log when this alarm occurs.
 - Send email: Select whether notification is sent by email when this alarm occurs.
- Input conditions:

You can select the bit from the M-Bus status byte for the device that represents the corresponding alarm notification.

Click **Save** to apply the alarm settings. You must confirm to apply the settings!

By selecting the check box, if multiple devices of the same type are installed on the plant, settings identified by (**) can be transfer the settings to all devices of the same type.

Save

Select this option to apply the settings marked with (**) to all devices of the same brand and model

8.4.3.2 Device search: M-Bus line M1M2 / M-Bus line ABC

You can either perform the device search individually on line M1M2 or line ABC respectively, or search both lines in parallel.

For device searches, you can select whether to use the default settings or to search by specific criteria.

The screenshot shows the EQUOBOX SINAPS I web interface. The user is logged in as Mario Rossi. The interface is in English. The left sidebar contains navigation options: Plant status, Settings (selected), 01 System, 02 Network, 03 Wired devices (selected), 04 Wireless devices, 05 Inputs/Outputs, Export data, and User account. The main content area shows a 'Device settings' tab with 'Device search - M-Bus line M1M2' selected. A progress bar indicates 'Secondary address search in progress' at 60%. Below the progress bar, it shows 'Current address: 6XXXXXXXX' and 'Current baudrate: 2400 bps'. A 'Stop' button is visible. Below the progress bar, it shows 'Total devices found: 11' and 'New devices found: 6'. A table lists the found devices with columns for Serial number, Primary address, Medium, Manufacturer code, and Device name.

Serial number	Primary address	Medium	Manufacturer code	Device name
47821116	13	Heat	HON	DEV_47821116
42550093	12	Heat/Cooling	EFE	DEV_42550093
05421535	4	Electricity	LSE	DEV_05421535
05421534	3	Electricity	LSE	DEV_05421534
00000280	9	Warm Water	LSE	DEV_00000280
00000180	47	Water	LSE	DEV_00000180
23282974	11	Heat	EFE	DEV_23282974
15550082	10	Water	MAD	DEV_15550082
10485502	2	Warm Water	REL	DEV_10485502
10485501	1	Water	REL	DEV_10485501

The entire bus is scanned for connected M-Bus devices if **Use default settings** is selected and you click **Start scan**.

Note: Start by scanning with **Use default settings**. Only use the customized device search if the search by default settings fails to recognize one or more devices. This can be the case if a data collision occurs on the bus during the automatic search or if the device does not operate at the standard baud rate. Refer to the device documentation for the data.

Using default setting the datalogger searches for devices by the secondary address at a baud rate of 2400 bps.

Customized search: M-Bus line M1M2 / M-Bus line ABC

Unchecking **Use default settings**, you can customize the type of search for devices on the bus.

Serial number	Primary address	Medium	Manufacturer code	Device name
66660211	16	Heat	LUG	DEV_66660211
66071928	14	Heat	LSE	DEV_66071928
47821116	13	Heat	HON	DEV_47821116

You can customize a search to search by the following criteria:

- Primary address
- Secondary address
- Baud rate

Search by primary address:

You can select or clear a search by primary address.

- First address: You can define the start address for the search
- Last address: You can define the end address for the search
- Single address: You can scan by a specific primary address.

Search by secondary address:

You can select or clear a search by secondary address (serial number).

Serial number	Primary address	Medium	Manufacturer code	Device name
66660211	16	Heat	LUG	DEV_66660211
66071928	14	Heat	LSE	DEV_66071928
47821116	13	Heat	HON	DEV_47821116
42550093	12	Heat/Cooling	EFE	DEV_42550093

To shorten the search time, you can limit the search range for secondary addresses using the settings for Digit 1 through Digit 8.

Search baud rate:

You can enter the corresponding baud rate for the device search if devices deviate from the default baud rate (refer to the device documentation for the baud rate). You can search for devices by a specific baud rate (300 / 600 / 1200 / 2400 / 4800 / 9600 bps). Multiple baud rates can be selected as well. The device search is longer, if multiple baud rates are selected at the same time.

Click **Start scan**.

Progress is indicated by the progress bar.

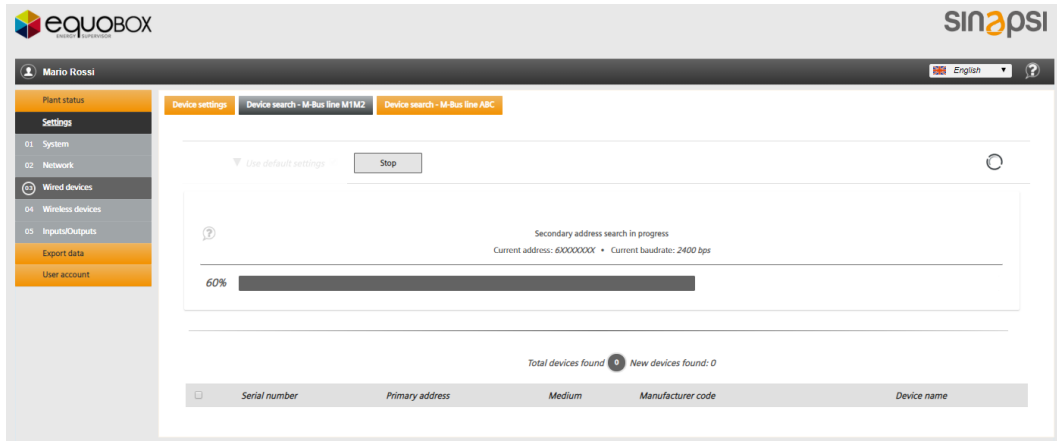

Search results

All found devices are listed at the conclusion of the device search. Select one or more devices and Add, to add the new devices to the device list.

Important! Devices that are not saved are rejected.

The following must be listed at a minimum for any found device:

- Serial number
- Primary address
- Medium
- Manufacturer code with optional device image
- Automatically generated device name.

8.4.4 Wireless devices

8.4.4.1 Device settings

In this panel, you have access to the list of M-Bus wireless devices and can change the settings.

Note The list is empty if no device search has been performed. Found and saved devices are displayed in the list after a device search.

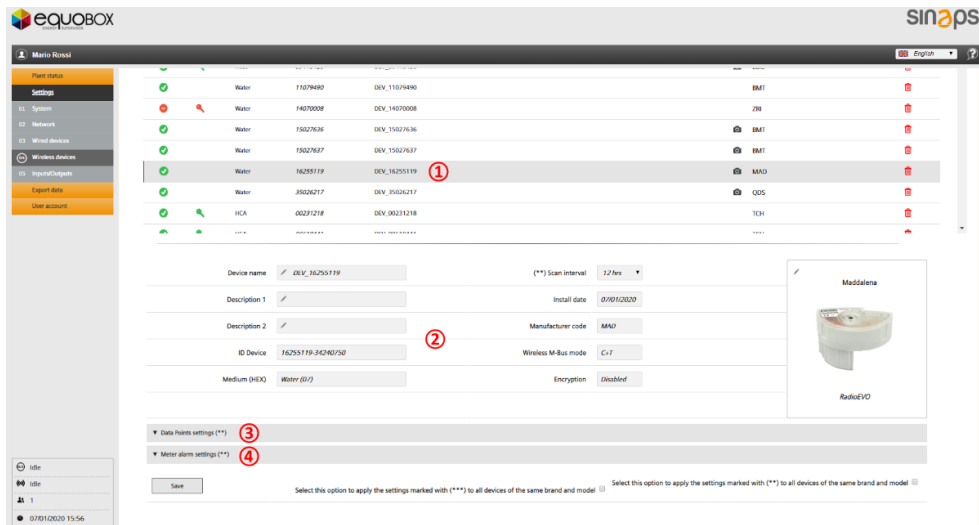

The display is structured as follows:

1. List of all devices found on M-Bus
2. Device settings
3. Data points settings
4. Meter alarm settings

Also, it is possible:

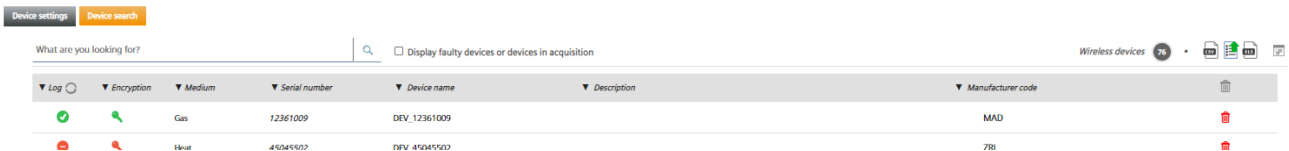

- To search a device
- To display only faulty devices or devices in acquisition
- Display all the saved meters
- To export the list of wireless devices as an .xls or .csv file clicking the corresponding symbol:



Serial number	Device name	Description	Manufacturer code	Medium	AES Key	Current status
14012862	DEV_14012862		BMT	Heat	NO	OK
16340213	DEV_16340213		ITW	Heat	NO	OK
15027636	DEV_15027636		BMT	Water	NO	OK
15027637	DEV_15027637		BMT	Water	NO	OK
16255119	DEV_16255119		MAD	Water	NO	OK

1. List of saved meters

Log	Encryption	Medium	Serial number	Device name	Description	Manufacturer Model	Scan interval	
✓	🔒	Gas	12361009	DEV_12361009		MAD	12 hrs	🗑️
✗	🔒	Heat	45045502	DEV_45045502		ZRI	12 hrs	🗑️
✓		Heat	68262279	DEV_68262279		📷 Siemens T230-A21C	12 hrs	📈 🗑️
✓		Heat	68431626	DEV_68431626		📷 Siemens UH50+WZU-RF	1 day	🗑️
✗	🔒	Heat	69017403	DEV_69017403		LUG	60 min	🗑️
✗	🔒	Heat	69017404	DEV_69017404		📷 Siemens T230	1 day	🗑️
✓		Heat	69123455	DEV_69123455		📷 Siemens UH50	1 day	🗑️

- **Log:** Indicates whether the device was accepted or not
- **Encryption:** Indicates whether the device is encrypted
- **Medium:** Displays the medium
- **Serial number:** Displays the meter serial number
- **Device name:** Displays the meter name as entered under device name
- **Description:** Displays the text entered under Description 1
- 📷 : Indicates that a product image is available for the device.
- **Manufacturer/Model:** Displays the 3-letter code of the manufacturer of the device if it is not already integrated in the "Presetting meter list" (meter readable but not pre-configured for reports). Otherwise it shows the manufacturer in full and the model of the M-Bus device.
- **Scan Interval:** Indicates the frequency with which the datalogger automatically queries the M-Bus meter to receive data.
- 📈 **Trend Report:** Indicates whether the device has configured at least one datapoint such that it is included in the Trend Report. Delete - click on the recycle bin to delete the device from the list.
- **Delete:** Click the trash can to delete the device from the list.

2. Selected meter settings

Click the device line to view the settings for the device:

Device name	<input type="text" value="DEV_16255119"/>	(**) Scan interval	<input type="text" value="12 hrs"/>	 <p>Maddalena</p> <p>RadioEVO</p>
Description 1	<input type="text"/>	Install date	<input type="text" value="26/07/2017"/>	
Description 2	<input type="text"/>	Manufacturer code	<input type="text" value="MAD"/>	
ID Device	<input type="text" value="16255119-34240750"/>	Wireless M-Bus mode	<input type="text" value="C+T"/>	
Medium (HEX)	<input type="text" value="Water (07)"/>	Encryption	<input type="text" value="Disabled"/>	

Free text settings:

- **Device name:** You can assign a name to the device (e.g. Apartment 123).
- **Description 1:** Device description as indicated in the device list.
- **Description 2:** Additional description
- **Scan interval:** 15 min. / 60 min., 6 h, 12 h, 1 day, 7 days, 1 month
- **Installation date:** you can add an installation date
- The device image can be set by clicking the  as needed. You can select the appropriate image from the datalogger device database.

Click **Save** to save the edited values.

Settings that cannot be changed:

- **ID Device:** Displays the device serial number
- **Medium (HEX):** Displays the medium measured by the device.
- **Manufacturer code:** Displays the manufacturer's code (if included in the database).

- **Wireless M-Bus mode:** Indicates the communication mode of the device between C+T, T, S, C+T & S
- **Encryption:** Indicates whether encryption is enabled or disabled.

3. Data points settings

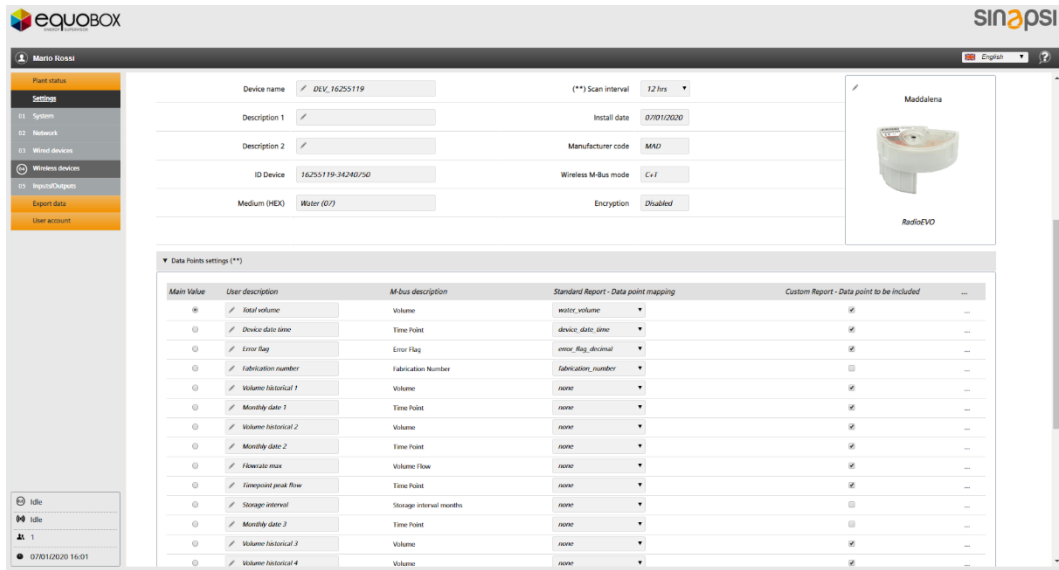

- **Main Value:** You can select the value for display on the **Plant status/Wireless** overview
- **User description:** The data point designation can be edited.
- **M-Bus description:** Designation of the data point according to the M-Bus specification
- **Standard report - Data point mapping:** Assigns data points to predefined columns on the standard report. Only one data point can be assigned to a specific column for each device. Data points with the "none" settings are not displayed in the standard report.
- **Custom Report - Data point to be included:** Select the data points to be included in the custom report.
- **Trend Report - Data point to be included:** Select the data points to include in the trend report. This report includes only the data points selected in the relevant column.
- **"...":** Click the "..." column to display additional details (Multiplier, Memory, Subunit, Rate, Value Type, and Unit) about the selected data point. The details can help you provide a meaningful user description.

Main Value	User description	M-bus description	Standard Report - Data point mapping	Custom Report - Data point to be included	Trend report - Data point to be included (X)	...
<input checked="" type="radio"/>	Energy	Energy	none	<input checked="" type="checkbox"/>	<input type="checkbox"/>	...
Private	1					
Subunit	0					
Storage	0					
Tariff	0					
Type value	Instantaneous Value					
Multiplier	0.001					
Units	MWh					

Click **Save** to save the changed settings

4. Alarms settings meters

Each device has a series of error messages available to it over M-Bus

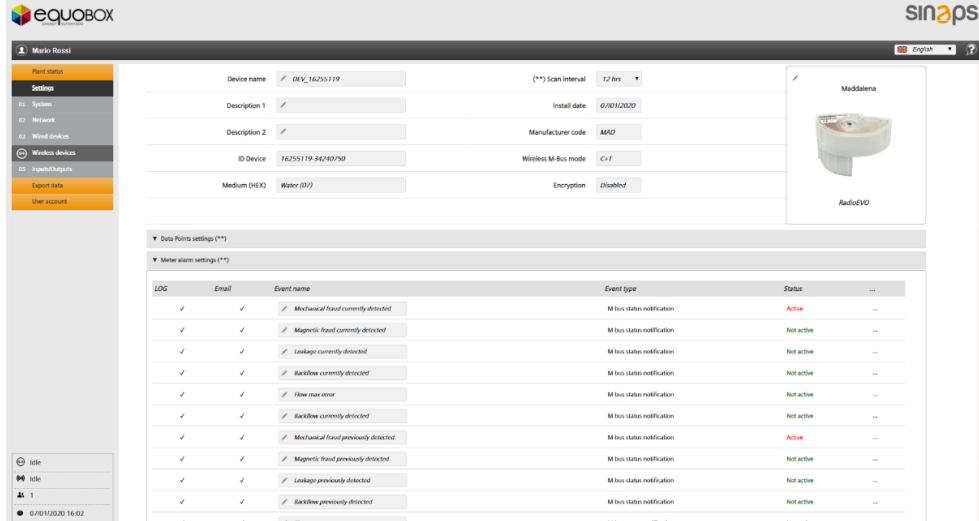

The following information and settings are available.

- **LOG:** When an error occurs, displays whether the message is recorded in the event log.
- **Email:** When an error occurs, displays whether an email is sent with the error message.
- **Event name:** The name of the event is default. However, it can be changed as needed.
- **Event type:** Displays the type of event received by the device.
- **Status:** Displays whether the alarm is active or not.

LOG	Email	Event name	Event type	Status	...																
✓	✓	✎ Error F3 F4 F7 F8	M-bus status notification	Not active	...																
<p>Actions <input checked="" type="checkbox"/> Add to log <input checked="" type="checkbox"/> Send email</p> <p>Input condition</p> <table border="0"> <tr> <td>Bit 7</td> <td>Bit 6</td> <td>Bit 5</td> <td>Bit 4</td> <td>Bit 3</td> <td>Bit 2</td> <td>Bit 1</td> <td>Bit 0</td> </tr> <tr> <td><input type="checkbox"/></td> <td><input type="checkbox"/></td> <td><input type="checkbox"/></td> <td><input type="checkbox"/></td> <td><input type="checkbox"/></td> <td><input checked="" type="checkbox"/></td> <td><input type="checkbox"/></td> <td><input type="checkbox"/></td> </tr> </table>						Bit 7	Bit 6	Bit 5	Bit 4	Bit 3	Bit 2	Bit 1	Bit 0	<input type="checkbox"/>	<input type="checkbox"/>	<input type="checkbox"/>	<input type="checkbox"/>	<input type="checkbox"/>	<input checked="" type="checkbox"/>	<input type="checkbox"/>	<input type="checkbox"/>
Bit 7	Bit 6	Bit 5	Bit 4	Bit 3	Bit 2	Bit 1	Bit 0														
<input type="checkbox"/>	<input type="checkbox"/>	<input type="checkbox"/>	<input type="checkbox"/>	<input type="checkbox"/>	<input checked="" type="checkbox"/>	<input type="checkbox"/>	<input type="checkbox"/>														

Click "... " to open a new panel with the following settings:

- **Actions:**
 - **Add to log:** Select whether this alarm is added to the event log.
 - **Send email:** Select whether notification is sent by email when this alarm occurs.
- **Input conditions:**
You can select the bit from the M-Bus status byte for the device that represents the corresponding alarm notification.

Click **Save** to apply the alarm settings. You must confirm to apply the settings!

By selecting the check box, if multiple devices of the same type are installed on the plant, settings identified by (***) can be transfer the settings to all devices of the same type.



8.4.4.2 Device Search

For device search, you can select whether to search for a gateway on a specific mesh network or for a wireless meter that communicates with a specific gateway within an M-Bus radio network.

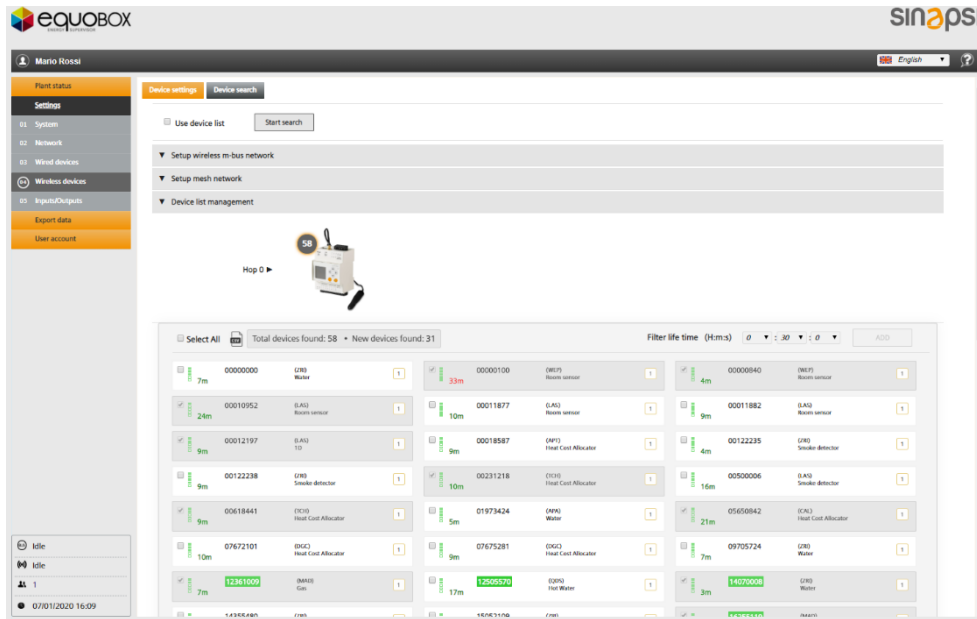

Setup Wireless M-Bus

The gateway and wireless devices communication over the M-Bus wireless network.

Settings that can be freely edited:

- Global encryption key: The global encryption is used during the automatic search. A global cryptographic key takes effect on all meter communications that support it.
 - Global AES Key 1: The global encryption key is used during the automatic search.
 - Global AES Key 2: The global encryption key is used during automatic search.
- M-Bus wireless operation mode: You can enter the M-Bus operation mode.

The following values are available: S, T, C+ T, S & C + T.

You can further limit the search to devices in installation mode only (SND_IR) or/and the walk-by devices.

- Acquisition phase duration: You can enter the duration of the device search in hours (1 to 24).

Click **Save** to save the changed values.

▼ Setup wireless m-bus network

Enable global encryption key

Global AES Key 1 ?

Global AES Key 2 ?

Operating Modes of Wireless M-Bus C+T ? During the scan, accept only devices that transmit in Installation mode (SND_IR)

Acquisition phase duration 12 Hours

Configure mesh network

SIN.EQRTUEVO2T and gateway communicate over a mesh RF protocol (Backbone network). Settings that can be freely edited:

- Mesh ID: You can enter the mesh ID for the mesh network. Ensure that all gateways are on the same mesh network.
- Channel: It is advisable to change this option only upon indication of the Sinapsi SRL operators in case of faults. Make sure all gateways are on the same mesh channel.



Click **Save** to save the changed values.

Click **Start search** to start the search.

The wireless symbol flashes while searching



Device list management

This option simplifies the commissioning and management of the plant. In fact, by uploading a .csv or .rpt file where all the desired meters are listed, it is possible to view the meters already found and those still that are not. In addition, the list allows you to have a clear and simplified registry for each of them.

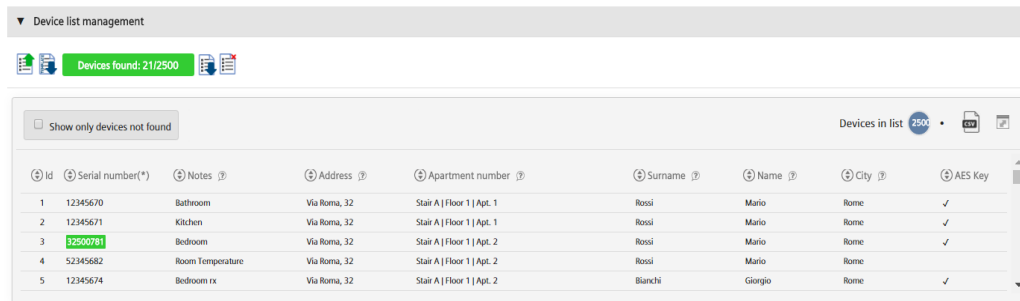

In fact, the following information of the meters explained with an example is displayed:

id	Serial Device	Note	Address	Internal	Surname	Name	City	AES Key
1	12345678	Bathroom	Fifth Avenue	1-A	Apartment A	Floor1	New York	✓
2	11223344	Living room	Fifth Avenue	2-A	Apartment B	Floor2	New York	✓

Important! Using the list also greatly simplifies the addition of the AES cryptographic keys of the meters that need it. In fact, in addition to being able to insert them individually by selecting them from the *Device Settings* section, these can be inserted simply by adding them on the corresponding row of the counter on the list to be loaded.

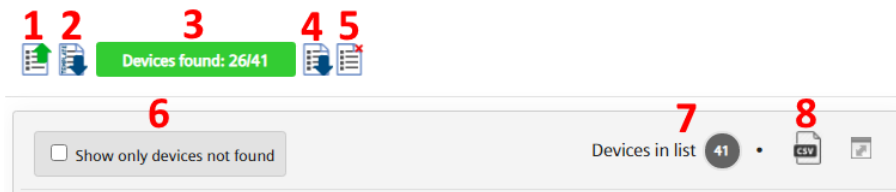

1. Click to upload a list on datalogger
2. Download a list template
3. Display the founded devices
4. Download the current list file
5. Delete the current list
6. Show only devices not found
7. Display the devices in list
8. Download the current list with current status

Search results

All devices found are listed under the image of the SIN.EQRTUEVO2T. Select one or more devices and click **Add** to add and then save and manage the desired new meters.

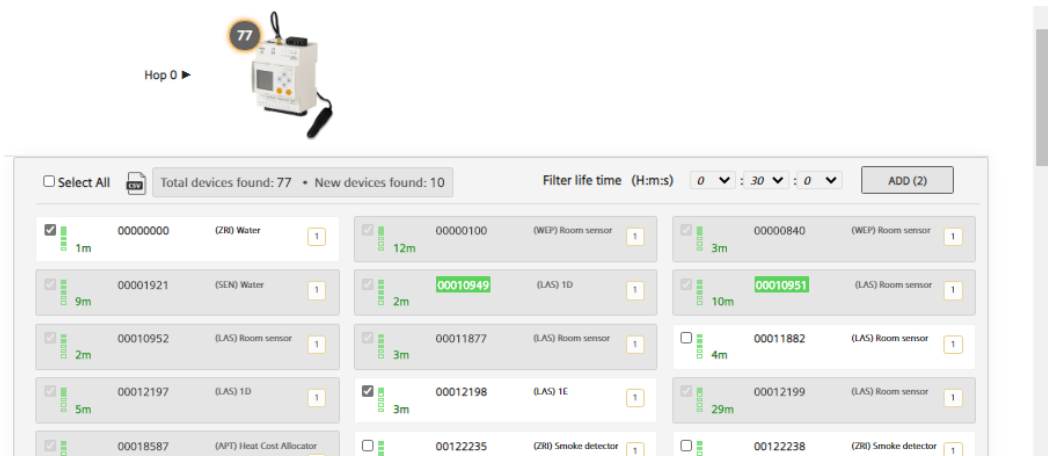

For any found device, are displayed the following information:

- Serial number
- Strength of signal
- Last communication
- Manufacturer code
- Medium
- Number of gateways that reached the wireless device

Important! Devices that are not saved are not managed by the system.

8.4.5 Inputs/Outputs

The SIN.EQRTUEVO2T has three digital inputs (I1, I2, I3) and 2 digital outputs (O1, O2).

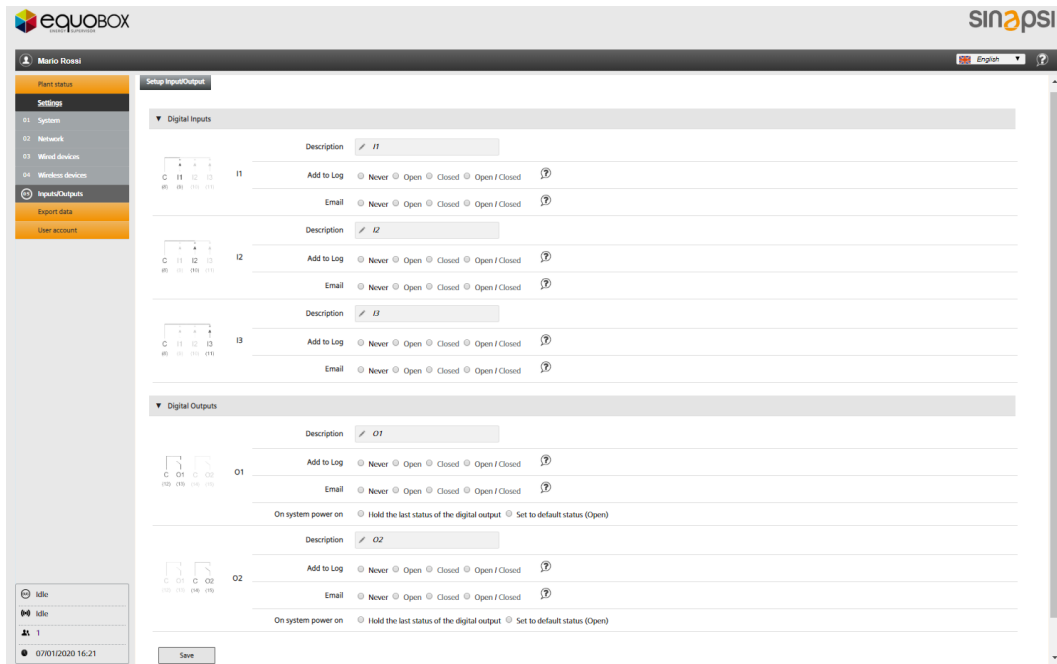

The following settings are possible on each digital input and output:

- Description: Each input/output can be labelled with an individual name.
- Add to log: Select whether to log a change of state to an input/output in the event log:
 - Never
 - Open: Only if the state is open or changes to open.
 - Closed: Only if the state is closed or changes to closed.
 - Open/close: For any change of state.
- Email: Select whether to send an email (see Settings / System / Alarms), if the input/output registers a change of state:
 - Never
 - Open: Only if the state is open or changes to open.
 - Closed: Only if the state is closed or changes to closed.
 - Open/close: For any change of state.

You can also select the output state for an output after a loss of power:

- Hold the last output state.
- Set to default state "open".

Click **Save** to save the edited settings.

8.5. Export data

Data logged by datalogger can be exported as a report for further processing.

There are two ways to create a report:

- Manual reports
- Automatic reports

8.5.1 Manual reports

8.5.1.1 Create report

The meters for which you want a report, must be selected. The wired ones must be read before creating a report, otherwise, as is the case for wireless meters, the latest saved data will be available with time interval as per setting (see paragraphs 8.4.3.1 *Devices settings* and 8.4.4.1 *Device settings* respectively for wired and wireless devices). Click Read Now to read the devices in the list.

Select the devices to be included in the report.

Select the check box in the title line to select all the devices on the list.

Note To simplify the search for the desired device, sort the list alphabetically by clicking

The following selections need to be made before you can generate the report:

- Report type (select between):
 - Standard report: This report includes only the data points on devices that were assigned a standard column in the device settings (see *Data points settings*).

Report type **Standard Report** Select day **2021-08-04** File type **xls**

- Customized report: This report includes only data points on devices selected in the Customized report column in device settings (see *Data points settings*).

Report type **Custom Report** Select day **2021-08-04** File type **xls**

- Report all data: This report includes all data points from all devices.

Report type *All Data Report* Select day *2021-08-04* File type *xls*

For the report templates described above, other choice options are also displayed:

- Select day: Select the read date of devices data used for the report. The current date is always the default date. You can also select a date in the past.
- File type: Select one of the following file formats:
 - .csv format: Exports the data as a .csv file.
 - .xls format: Exports the data as an .xls file.
 - .txt format: Exports the data as a .txt file.

You can also download an additional type of report in .csv format only:

- Trend Report: this report includes only the data points on the devices selected in the "Trend report - Data points to include" column in the device settings (see Data points settings).

Tipo di report *Report Trend* Data inizio *2021-07-05* Ora Inizio *00* : *00* Carratteristiche del Trend Report
 N. dispositivi: 8
 N. Data Point: 13
 Intervallo campioni: 15min
 N. Letture: 95

Data fine *2021-07-05* Ora fine *23* : *45*

You can select other options for the Trend Report and view other information:

- Start Date: Select the detection start date.
- Start Time: Select the start time of the survey.
- End Date: Select the end date of the trend report.
- End Time: Select the end time of the trend.
- Trend Report Features: The following is displayed:
 - the number of devices of which there is at least one datapoint selected for the report
 - the number of datapoints of all devices
 - Sample Interval: The shortest interval is displayed, where the reading intervals are different for the selected device datapoints.
 - Number of Readings: The number of total readings you will have on the Trend Report with the selected features.

Please note: There is no software limit such that the total number of readings on the Trend report is limited. However, the higher the number of readings to be reported, the more hardware resources are required for generation. Therefore it may happen that, if the total number of readings is excessive, the web server may have difficulty in correctly creating this type of report. It is advisable, therefore, if the reading interval should be rather frequent, not to exceed 10 days of detection.

Click **Create report** to generate the report and start the download. The filename is automatically generated. Additional information on the various report types is available in section "8.5.3 Creating reports".

8.5.2 Automatic reports

Read and post now, immediately reads all the devices on the overview list and sends the data per the settings below.

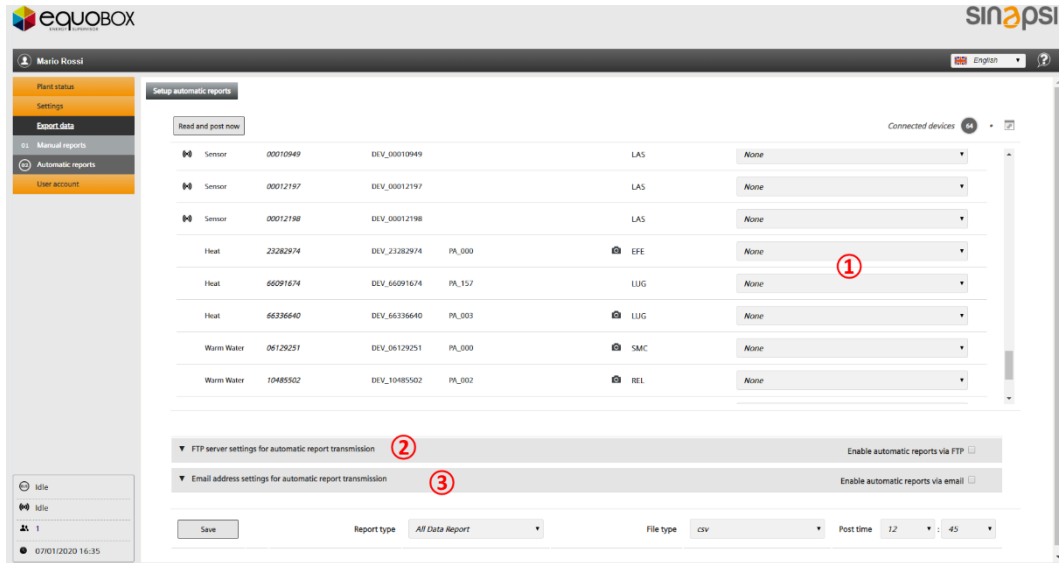

The following data is available on each device:

- Medium
- Serial number
- Device name
- Description
- Manufacturer code
- Report interval

8.5.2.1 Report interval

Select the interval for generating report.

①

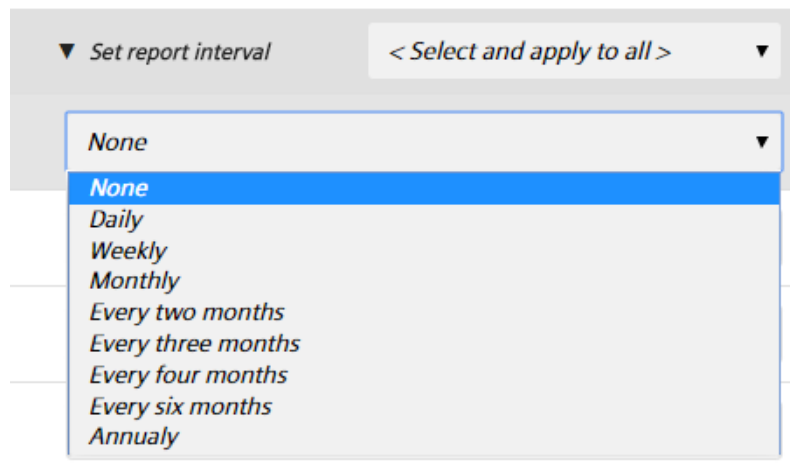

The following options are available:

- None: No report is generated.
- Daily: The report is generated daily at “post time” for the previous 24 hours.
- Weekly: The report is generated on Monday at “post time” for the last week.
- Monthly: The report is generated on the last day of the month at “post time”.
- Every two months: The report is generated on the last day of the second month at “post time” for the last two months.
- Every three months: The report is generated on the last day of the third month at “post time” for the last three months.

- Every four months: The report is generated on the last day of the fourth month at “post time” for the last four months.
- Every 6 months: The report is generated on the last day of the sixth month at “post time” for the last six months.
- Annually: The report is generated on the last day of the year at midnight for the previous year.

Selecting a report interval in the title applies the setting to all devices on the list.

Click **Save** to save your entries.

8.5.2.2 Set up FTP server for automatic report transmission

Select **Enable automatic reports via FTP** if each report is sent to an FTP server and enter the FTP server information.

2

- FTP server name: Enter the address for the FTP server
- Path (Remote): You can enter a path on the FTP server for saving reports.
- FTP server port: Enter the port for the FTP server
- FTP protocol: Select the FTP protocol. The following protocols are available:
 - SFTP – File Transfer Protocol (SSH)
 - FTP – File Transfer Protocol (TLS)
 - FTP – Unencrypted (unsecured)
- We recommend against using “FTP- unencrypted” for security reasons.
- Username: Username to access the FTP server.
- Password: Password for FTP server access

Click **Server connection test** to test the connection to the FTP server. The file ftp_test_connection.txt is saved to the FTP server.

Click **Save** to save your entries.

8.5.2.3 Set up email address for automatic report transmission

Select **Enable automatic reports via email** to send a report to one or more email addresses and enter the corresponding email addresses including the subject line.

3

- To: Recipients. You can separate individual addresses with a semicolon (;) if a report is sent to multiple addresses.
- Cc: Copy knowledge
- Ccn: Hidden knowledge copy
- Subject: Subject of the email

Click **Save** to save your entries.

8.5.2.4 Selecting report type

Before saving the automatic report settings, you can choose the type of report you want to receive:

- Standard Report: this report includes only the data points of the devices that have been assigned a column in the "*Standard Report - Data Points Association*" in the device settings (see Data points settings).

Save Report type Standard Report File type csv Post time 09 : 45

- Custom Report: this report includes only the data points of the devices selected in the "*Custom Report - Data points to be included*" column in the device settings (see Data points settings).

Save Report type Custom Report File type csv Post time 09 : 45

- All Data Report: this report includes all data points on all devices.

Save Report type All Data Report File type csv Post time 09 : 45

- Trend Report: this report includes only the data points on the devices selected in the "*Trend report - Data points to be included*" column in the device settings (see Data points settings).

Save Report type Trend report Post time 09 : 45

Note: The Trend Report will have data only for the day the email was received from midnight until it is generated and sent.

For the report templates described above, other choice options are also displayed:

- Send time: select the time the report is to be sent.
- File type: select one of the following file formats (*):
 - .csv: Exports data as a .csv file.
 - .xls: Exports the data as an .xls file.
 - .txt: Exports the data as a .txt file.

Note: Trend Report is available only in .csv file format

For all report templates, click SAVE to receive the report automatically. The file name is generated automatically. More information about the different types of reports can be found below in "8.5.3 Creating reports".

8.5.3 Creating reports

Reports can be sent via

- E-mail
- FTP server

8.5.3.1 Email

The email looks as follows

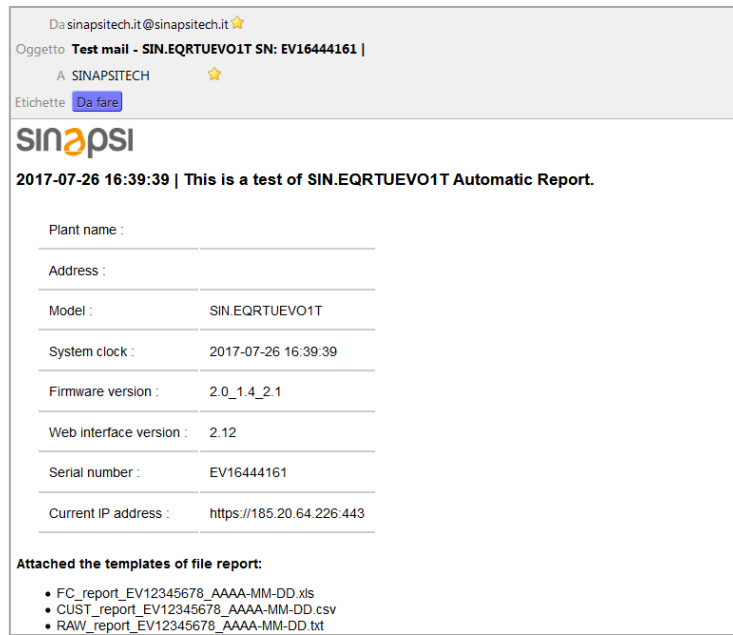

- Header: See settings in Section “Automatic reports”.
- Plants: Displays the name of the read file including the datalogger serial number, creation date and time.
- Plant information: Displays information on the object and datalogger (see System Status)

8.5.3.2 Standard report

The Standard report lists all read devices. A device corresponds to one line. Each column is the same for each device. The corresponding column is empty if a device does not have a certain value. The columns must be assigned to the corresponding data points in the device settings in the "Standard Report - Data points mapping" column, see Data points settings.

File Name	Report Date	Report Time	Plant Reference	Firmware version	Total devices cabled	Total devices wireless	Serial Number						
FC_report_EV12345678_AAAA-MM-DD.xls	DD/MM/AAAA	HH:mm:ss	Plant Address	x.yz x1.y1_x2.y2_x3.y3	k	0	EV12345678						
count	primary_address	device_serial_number	name_device	device_description	device_detail	device_measure_hex	0=wired 1=wireless	model_id	readout_date	readout_time	communication_status		

8.5.3.3 Customized report

A Customized report displays each device with two lines: The first line describes the content and the second the corresponding values. The number of columns varies by device and selected data points. Only the data points selected in the "Custom Report - Data point to be included" column in the device settings are listed, , see Data points settings.

File Name	Report Date	Report Time	Plant Reference	Firmware version	Total devices cabled	Total devices wireless	Serial Number									
CUST_report_DD/MM/AA/HH:mm:ss	DD/MM/AAAA	HH:mm:ss	Sinapsi_12	x.yz x1.y1_x k		0	EV12345678									
count	primary_add	device_serial	name_device	device_descr	device_detai	device_meas	0=wired 1=v	model_id	readout_dat	readout_tim	communicati	col 1	col 2	col 3	col 4	...

8.5.3.4 Report “All data”

Report all data displays each device with two lines: The first line describes the content and the second the corresponding values. The numbers of columns vary for each device depending on device type. All data points are listed that can be read.

File Name	Report Date	Report Time	Plant Reference	Firmware version	Total devices cabled	Total devices wireless	Serial Number							
raw_report_EV12345678_AAAA-MM-DD.csv	DD/MM/AAAA	HH:mm:ss	Sinapsi_12	admin - Admin123 - Via delle querce 11/13	x.yz x1.y1_x2.y2_x3.y3	k	0	EV12345678						
count	primary_address	device_serial_number	name_device	device_description	device_detail	device_measure_hex	0=wired 1=wireless	model_id	readout_date	readout				

Note The number in the reports are depicted as follows:

- Period as a decimal point separator

8.5.3.5 Trend Report

The Trend Report lists all reading ranges on the first column. A data point for a device corresponds to one column. If there are multiple data points for the same device, the corresponding readings will be set to multiple columns. The cell for the corresponding interval-column pair is empty if a device in that interval has no data point. In fact, the rows in the first column of the report show the shortest interval where the reading intervals are different for the data points of the selected devices. The columns should be assigned to the corresponding data point in the device settings in the "**Trend Report - Data points to include**" column see Data points settings

Data Report	Ora Report	Riferimento Impianto	Versione firmware	Totale dispositivi cablati	Totale dispositivi wireless	Numero di serie	Nome File		
05/07/2021	14:06:07	Sinapsi RTUEVOIT Demo 170 - Via delle Querce 11/13	3.40[4.9_2.0_3.1	11	69	EV16000193	TREND_report_EV16000193_2021-07-04_2021-07-04.csv		
Intervallo dati	15min								
Inizio	00:00:00		04/07/2021						
Fine	23:45:00		04/07/2021						
Numero di serie	[35022262]	[00012199]	[00012199]	[68262279]	[68262279]	[00000840]	[00000840]	[09705724]	[66071928]
Intervallo di Log	12ore	15min	15min	12ore	12ore	15min	15min	12ore	1giorni
Data Point	Volume totale (m3)	Temperature (C)	Humidity (%)	Consumo energia totale (kWh)	Volume totale (m3)	Temperature (C)	Humidity (%)	Volume Flow ext. (ml/s)	Energia riscaldamento (kW)
2021-Jul-04 00:00	0		29,5	40	0	0	29,2	40	
2021-Jul-04 00:15			29,5	40			29,2	40	
2021-Jul-04 00:30			29,5	40			29,2	40	
2021-Jul-04 00:45			29,4	40			29,3	40,1	
2021-Jul-04 01:00			29,4	40			29,3	40,1	
2021-Jul-04 01:15			29,4	40			29,3	40,1	
2021-Jul-04 01:30			29,4	40			29,3	40,1	
2021-Jul-04 01:45			29,4	40			29,3	40,1	
2021-Jul-04 02:00			29,3	40			29,3	40,1	
2021-Jul-04 02:15			29,3	40			29,3	40,1	
2021-Jul-04 02:30			29,3	40			29,3	40,1	
2021-Jul-04 02:45			29,3	40			29,3	40,1	
2021-Jul-04 03:00			29,3	40			29,3	40,1	
2021-Jul-04 03:15			29,3	40			29,4	40,1	

8.6. User account

The User account menu displays all registered users and creates a new user. In addition, all login attempts (*Users Access Logging*) are recorded. From this section it is also possible to generate the "API Authorization Key," which is the key useful for using the RTUEVO RESTful API.

Click **Exit** to log off datalogger.

8.6.1 User configuration

8.6.1.1 New User

The New user creates a new user account on datalogger.

At the same time, it provides information on all previously registered users, including access rights (user type).

Username	First name Last name	User Type	Email
admin	Mario Rossi	Administrator	admin@admin.it

First name Last name
 * Email * Username
 * Password * Confirm password
 * User Type

You must be logged in administrator to change user data or create a new user.

First name Last name
 * Email * Username
 * Password * Confirm password
 * User Type

Enter the new user data and click **Add**:

- First name
- Last name
- Email
- Username
- Password including
- Confirm password
- User type:
 - **User**: Users have a restricted view on datalogger and cannot change or enter settings.
 - **Maintainer**: Maintainers have a restricted view on datalogger. They can change or enter some settings compared to users.
 - **Administrator**: Administrators have access to all data and functions.

Menu	Administrator	Maintainer	User
Plant state	U	R	R
Settings	U	R	-
Export data	U	U	U
User account	U	-	-

U = Unrestricted access R = Restricted access - = no access

If you are an administrator in this section you can also manage previously registered accounts. It is possible to edit the data and save the changes made and change the type of access for each account.

Username	First name Last name	User Type	Email
admin	Mario Rossi	Administrator	marco.gubbiotti@sinapsitech.it
manutentore	Steve Ray Vaughn	Maintainer	srv@fender.com
user	Eric Clapton	User	ec@stratocaster.com

Form fields:

- First name: Mario
- Last name: Rossi
- * Email: marco.gubbiotti@sinapsitech.it
- * Username: admin
- * Old password: [empty]
- * Password: [empty]
- * Confirm password: [empty]
- * User Type: Administrator

API Authorization Key: Generate Endless (∞) [YWRtaW46YTo0OHUyS5hBeVdtRkc4WFBIUUU5c0A0TXVckFLMmRTRncpCY5Nw==]

User configuration: Save Delete

In addition, it is possible to view and generate the "API Authorization Key" for Administrator type accounts. For further guidance on the use of APIs, please refer to the section **WEB SERVICES: RESTful API**.

8.6.1.2 User access logging

All login actions are registered on datalogger.

Last Login	Logged	User	Tipo Utente	IP
2020-01-08 10:18:39	Connected	Mario Rossi (admin)	Amministratore	192.168.1.77
2019-12-18 17:58:30	Not Connected	Mario Rossi (admin)	Amministratore	192.168.1.226

The following information is retained for each login:

- Last login: Date & time the user logged in.
- Logged: User status.
- User: First and last name of the user
- User type: Administrator / Maintainer / User
- IP address: IP address of the PC used by the user to access datalogger

User access data is registered for the last 28 days.

8.6.2 Log off

Click **Exit** to log off datalogger without further warning.

9. WEB SERVICES: RESTful API

From the section **User Account** → **User configuration** → **New user** select a user of type Administrator.

The screenshot shows the 'New user' configuration page in the SINAPSI system. The user 'admin' is being configured with the following details:

Username	First name Last name	User Type	Email
admin	Mario Rossi	Administrator	marco.gubbiotti@sinapsitech.it
manutore	Steve Ray Vaughn	Maintainer	srv@fender.com
user	Eric Clapton	User	ec@stratocaster.com

Below the table, the form fields are filled as follows:

- First name: Mario
- Last name: Rossi
- * Email: marco.gubbiotti@sinapsitech.it
- * Username: admin
- * Old password: (empty)
- * Password: (empty)
- * Confirm password: (empty)
- * User Type: Administrator

The API Authorization Key section shows a 'Generate' button and a text box containing the key: YWRtaW46YTd0OHAYsFhBeVdlRkc4WFBkUUU5cFA0TXV6ckFLMmRTRnprcTY5Nw==.

Going to the **API Authorization Key** section, pressing the **Generate** button allows you to generate a key to be used for authentication when using the RESTful API.

Such a key can be generated for unlimited use over time or it can be generated with an expiration date:

The screenshot shows the API Authorization Key generation interface. The 'Expiration date' is set to 2024-08-04, and the 'Endless' checkbox is unchecked. The generated key is displayed in a text box.

Once the key has been generated, you need to press the **Save** button, to save the settings.

By pressing on the  button, if you are connected to the Internet, you can download the English-language manual "RTUEVO RESTful API" where all the endpoints and their use are indicated.

The "RTUEVO RESTful API" manual can also be downloaded from the following link:

http://download.snpds.com/snrtu/SINEQRTUEVO1T/manual/api/SIN.EQRTUEVO1T_API_STD_1.0_en.pdf

10. APPENDIX

10.1. Router configuration

9.1.1 Port forwarding

Normally is not necessary to set

Datalogger uses the following port:

- 443 (fixed port for HTTPS protocol)
- 1194 (fixed port for VPN)

To access the datalogger from the Internet, you must setup a port forwarding rule in the router to the IP address and port 443 of the datalogger. The external port number can be defined freely but has to be unique within the router.

The chosen external port number must also to be entered in the LAN settings.

10.2. Open Source Software

Open Source Software (OSS) is used on datalogger.

9.2.1 License information

The license texts of all Open Source Software packages can be viewed individually at



Third-Party Software Information







Warranty regarding further use of the Open Source Software:

License name	Size	Last Modified
1 ▶ Apache-2.0	11k	December 19, 2004
2 ▶ Artistic	6k	December 16, 1996
3 ▶ BSD	1k	August 26, 1999
4 ▶ GFDL-1.2	20k	March 24, 2010
5 ▶ GFDL-1.3	22k	November 03, 2008
6 ▶ GPL-1	12k	March 24, 2010
7 ▶ GPL-2	18k	March 24, 2010
8 ▶ GPL-3	34k	July 02, 2007
9 ▶ LGPL-2.1	26k	March 24, 2010
10 ▶ LGPL-2	25k	March 25, 2010
11 ▶ LGPL-3	7k	March 24, 2010

Package name	Size	Last Modified	Update
1 ▶ adduser	2k	May 15, 2012	
2 ▶ apt	1k	October 23, 2014	
3 ▶ base-files	1k	August 30, 2015	
4 ▶ base-passwd	1k	August 02, 2010	
5 ▶ bash	19k	September 25, 2014	

9.2.2 Tools for packages upgrading

All packages subject to a GPL-3 or LGPL-3 license must be made upgradable to experienced users for legal licensing reasons. The packages are labelled on the list with  .

6 ▶	binutils	2k	January 05, 2015	
7 ▶	bsdutils	1k	December 11, 2012	
8 ▶	ca-certificates	18k	September 24, 2014	
9 ▶	coreutils	12k	January 26, 2013	
10 ▶	cpio	1k	December 22, 2014	
11 ▶	cron	4k	July 03, 2012	
12 ▶	dash	3k	March 01, 2012	
13 ▶	dbus	11k	February 05, 2015	
14 ▶	debconf-i18n	3k	September 11, 2012	
15 ▶	debconf	3k	September 11, 2012	
16 ▶	debian-archive-keyring	1k	November 21, 2006	
17 ▶	debianutils	8k	June 28, 2012	
18 ▶	dialog	1k	March 03, 2012	
19 ▶	diffutils	2k	October 16, 2011	

Sinapsi regularly provides firmware updates to the datalogger. This occurs exclusively through firmware updates (online or offline). The tool for package upgrades is not required to operate and maintain the datalogger.

Important!

Caution: Datalogger can no longer be used as the M-Bus master as soon as a package is changed with this tool! Access to datalogger over web operation and local operation is no longer possible! All data is deleted on the datalogger for security reasons! This procedure can no longer be rescinded and a new datalogger must be purchased if the tool is accidentally used to update a package! Only the Linux base system remains on the device after completing a package update.

The device can then be accessed via an SSH connection through Ethernet port 192.168.1.110. Use username **root** and password **12345678**.

10.3. Web Access

The complete management of SIN.EQRTUEVO2T is done through its integrated web server.

The web server can be accessed and managed remotely. For this purpose, as for all web servers, it becomes necessary:

- Have available a static or dynamic IP address
- Create certain port-forwarding rules on the router (ADSL or mobile connection).

In case of mobile connection:

- Use a bidirectional machine-to-machine (M2M) SIM (with IP address, also called de-nated)
- Configure the router with the specific APN of the selected SIM

In order to optimize the timing and reduce the complexity of commissioning the SIN.EQRTUEVO2T system, the user is provided with the use of the Web Access service.

Web Access is a service that allows all users to reach the SIN.EQRTUEVO2T wherever they are in the world, as if they were connected via LAN:

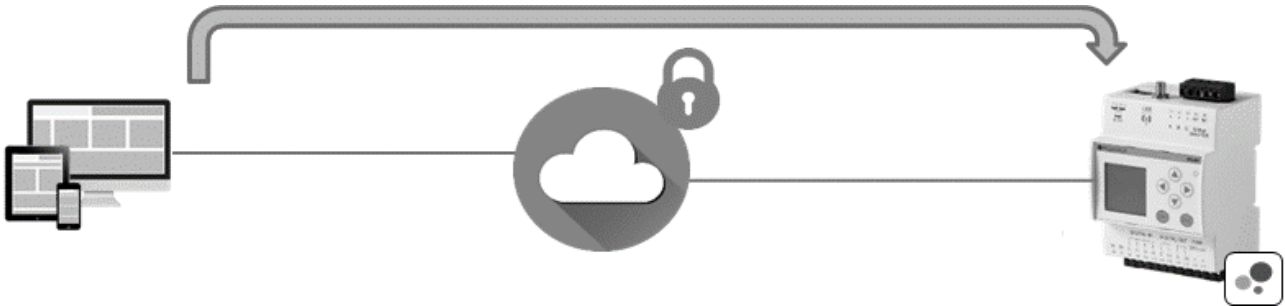

WEB ACCESS

1. Allows you to almost completely eliminate the configuration tasks mentioned above
2. Allows the use of simple machine-to-machine (M2M) SIMs without necessarily being bi-directional
3. Increases connection security by providing certified protection

